

Vehicle dimension limits

Purpose

To inform vehicle owners, operators and manufacturers of the dimension limits applying to vehicles registered for use on NSW roads.

Introduction

In NSW, the Road Transport (Vehicle Registration) Regulation 2007 (the Regulation) limits the overall dimensions relating to width, height and length, and some internal dimensions of vehicles.

These dimension limits are set to ensure that vehicles using the road network have adequate manoeuvrability and are compatible with the road systems and other road users. However, vehicles that are constructed or used for specific applications may be allowed to operate under the Road Transport (Mass, Loading and Access) Regulation 2005 (referred to as the 'MLAs'), or permit notices.

Classification

Vehicles are generally separated into two categories; 'general access vehicles' or 'restricted access vehicles'.

General access vehicles, including combinations, are those that are within the dimension requirements of the Regulation. In addition to meeting the dimension limits, a general access vehicle must not exceed its manufacturers Gross Vehicle Mass (GVM) or Gross Combination Mass (GCM) rating, or the mass allowed for the vehicle axle configuration under the 'MLAs', whichever is the lesser.

Restricted access vehicles, including combinations, are those that exceed either a general access dimension or mass limit and may only operate under a permit or notice issued by the Roads and Traffic Authority (RTA) Special Permits Unit – see page 20 for contact details.

Any vehicle that exceeds a general access dimension, is overmass, dual control or left-hand drive requires written approval from the RTA to be registered and to operate on NSW roads and road related areas. Exemption from the Regulation is considered on an individual basis; Vehicle Standards Information (VSI) No. 46 *Registration of non-conforming special purpose vehicles* contains a form to gather information on each vehicle to determine whether the vehicle may be registered, and if so, what operating conditions apply.

For further enquiries

RTA Technical Enquiries, PO Box 1120, Parramatta NSW 2124
T 1300 137 302 | F 02 9843 3821 | E tech-enq@rta.nsw.gov.au
www.rta.nsw.gov.au



Contents

Page

SECTION 1. MOTOR CYCLES	3
SECTION 2. RIGID VEHICLES	
A. General access rigid vehicles	
Truck - conventional load carrying type	3
Special Purpose Vehicle (SPV) other than a mobile crane	3
Mobile crane	3
B. Restricted access rigid vehicles	
Special Purpose Vehicle (SPV) up to and including 14.5 metres, other than a mobile crane	4
Mobile crane up to and including 14.5 metres	4
SECTION 3. TRAILERS	
A. General access trailers	
Dog trailer (including plant)	5
Pig trailer (including plant)	5
Semi-trailer, including plant and car carrier	6
Low loader trailer	6
B. Restricted access trailers	
Low loader trailer with eight tyres on each axle	7
Class 3 semi-trailer up to 14.63 metres	8
Refrigerated semi-trailer up to 14.9 metres	8
SECTION 4. BUSES, INCLUDING COACHES	
A. General access buses	
Bus/coach up to 12.5 metres	9
Articulated ('bendy') bus	9
B. Restricted access buses	
Controlled access bus/coach over 12.5 metres up to 14.5 metres	9
SECTION 5. COMBINATIONS/ARTICULATED VEHICLES	
A. General access combinations	
Truck and dog trailer	10
Truck and pig trailer	10
Prime mover and semi-trailer	10
Prime mover and low loader trailer	10
B. Restricted access combinations	
Truck and dog trailer – hauling unit exceeds 42.5 tonnes GCM	11
Prime mover and low loader trailer – trailer fitted with eight tyres on each axle	11
Car carrier – prime mover and semi-trailer; not designed to carry load over cab	12
Car carrier – prime mover and semi-trailer; designed to carry load over cab	12
Car carrier – rigid truck and semi trailer	13
Prime mover and semi-trailer towing a converter dolly	13
B-Doubles	14
Road trains	14
SECTION 6. GENERAL REQUIREMENTS	
Height	16
Width	16
Projection of mirrors	16
Ground clearance	16
Turning circle (vehicles other than articulated buses)	17
Projecting loads & equipment	17
Rear overhang	17
Steerable axle/s	18
Retractable axle/s	18
Axle groups	18
Load sharing axle groups	19
SECTION 7. AGRICULTURAL VEHICLES	19
SECTION 8. GLOSSARY	19
SECTION 9. CONTACT DETAILS FOR ADDITIONAL INFORMATION	20

Section I. Motor cycles

For dimension limits on motorcycles see VSI 28 *Guidelines for modifications to motor cycles*.

Section 2. Rigid vehicles

A. GENERAL ACCESS RIGID VEHICLES

The dimensions shown in this section are the maximum allowable for general access rigid vehicles as defined in the Regulation. In addition to the following limits, general access vehicles must meet other requirements as described in Section 6 'General requirements' on pages 16 to 19.

For rigid vehicles exceeding any dimension(s) shown in this section, refer to Section 2B 'Restricted access rigid vehicles' on page 4.

TRUCK - CONVENTIONAL LOAD CARRYING TYPE

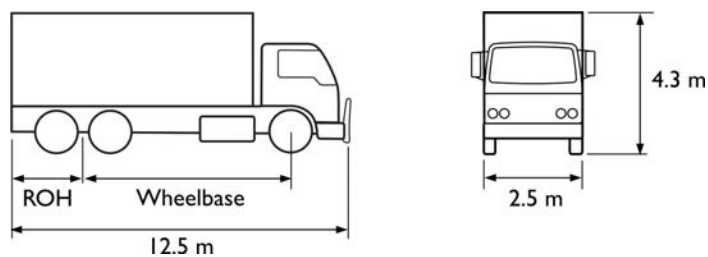

Rear overhang (ROH): 60% of the wheelbase or 3.7 metres, whichever is the lesser.

SPECIAL PURPOSE VEHICLE (SPV) OTHER THAN A MOBILE CRANE

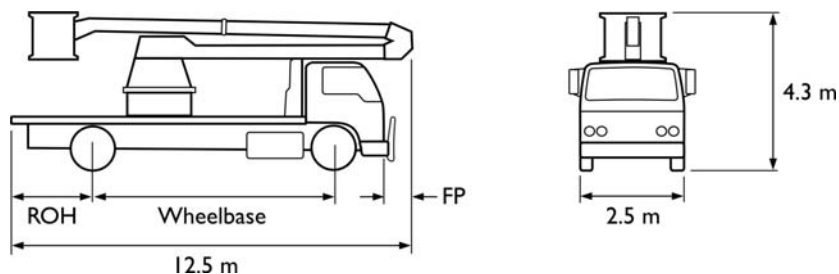

Rear overhang (ROH): 60% of the wheelbase or 3.7 metres, whichever is the lesser.

Forward projection (FP): 1.2 metres in front of headlights, included in overall length.

MOBILE CRANE

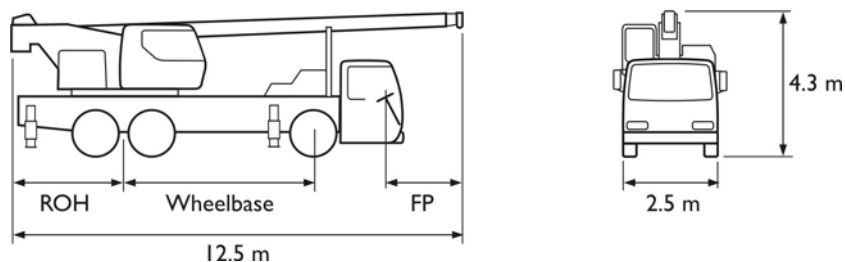

Rear overhang (ROH): 60% of the wheelbase or 3.7 metres, whichever is the lesser.

Forward projection (FP): 3.5 metres from centre of steering wheel, included in overall length.

B. RESTRICTED ACCESS RIGID VEHICLES

The dimensions shown in this section are the maximum allowable for rigid vehicles that exceed any of the general access dimensions described in Section 1A on page 3. Unless otherwise approved, restricted access vehicles must also meet all other requirements described in Section 6 'General requirements' on pages 16 to 19.

A restricted access vehicle requires approval from the RTA to be registered and to operate on NSW roads, as does any vehicle that is overmass, dual control or left-hand drive.

Specific vehicles in this category, including multiple deck livestock or primary produce transporters operating on prescribed routes, and car carriers carrying vehicles on more than one deck, may exceed a height of 4.3 metres but are limited to a maximum height of 4.6 metres. In this case the vehicle must operate under the '4.6 Metre High Vehicle Route Notice 2008'.

SPECIAL PURPOSE VEHICLE (SPV) UP TO AND INCLUDING 14.5 METRES, OTHER THAN A MOBILE CRANE

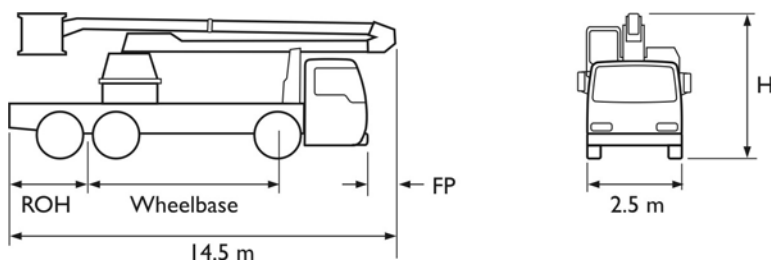

Rear overhang (ROH): 90% of the wheelbase or 4.0 metres, whichever is the lesser.

Forward projection (FP): 1.2 metres in front of headlights, included in overall length.

Height (H): Height may exceed 4.3 metres but is limited to a maximum of 4.6 metres if operating under the '4.6 Metre High Vehicle Route Notice 2008'.

MOBILE CRANE UP TO AND INCLUDING 14.5 METRES

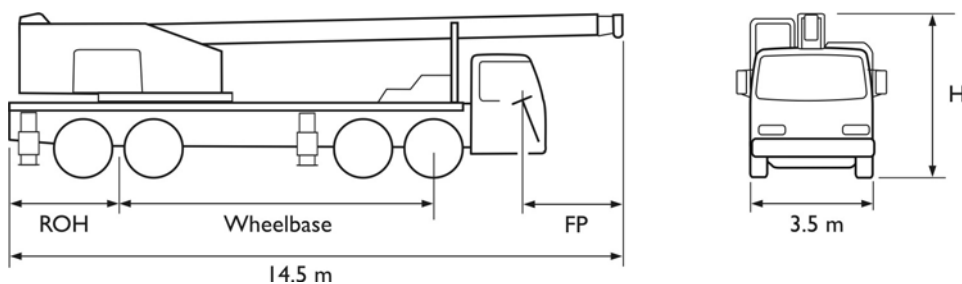

Rear overhang (ROH): 90% of the wheelbase or 4.0 metres, whichever is the lesser.

Forward projection (FP): 3.5 metres from centre of steering wheel, included in overall length.

Height (H): Height may exceed 4.3 metres but is limited to a maximum of 4.6 metres if operating under the '4.6 Metre High Vehicle Route Notice 2008'.

Section 3. Trailers

A. GENERAL ACCESS TRAILERS

The dimensions shown in this section are the maximum allowable for general access trailers as defined in the Regulation. In addition to the following limits, general access trailers must meet all other applicable requirements as described in Section 6 'General requirements' on pages 16 to 19.

For trailers exceeding any dimension(s) shown in this section, refer to Section 3B 'Restricted access trailers' on pages 7 and 8.

Trailers that otherwise exceed the dimension limits set out in this publication or are overmass require approval from the RTA for registration (see 'Classification' on page 1).

DOG TRAILER (INCLUDING PLANT)

A 'dog' trailer is a trailer that has a front axle or axle group steered by a drawbar attached to a towing vehicle, and a rear axle or axle group. A combination consisting of a semi-trailer and a converter dolly is also considered to be a dog trailer.

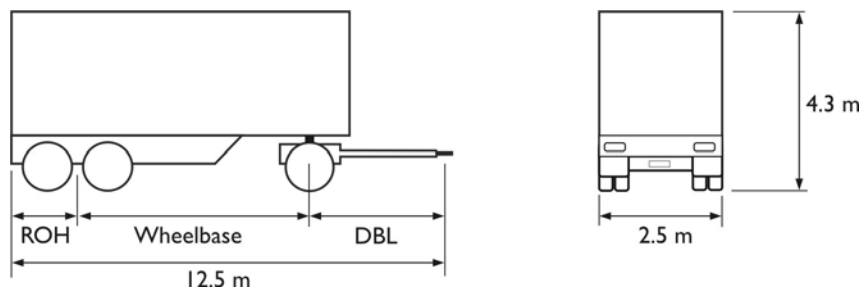

Rear overhang (ROH): 60% of the wheelbase or 3.7 metres, whichever is the lesser.

Drawbar length (DBL): Measured from the centre of the front axle/axle group to the centre of the drawbar coupling pivot point with the drawbar level, must:

- Not be more than 5 metres, and
- Not be less than 3 metres in the case of a trailer used in a road train over 19 metres in length,

PIG TRAILER (INCLUDING PLANT)

A 'pig' trailer is a trailer that has only one axle group near the middle of the length of the goods carrying surface.

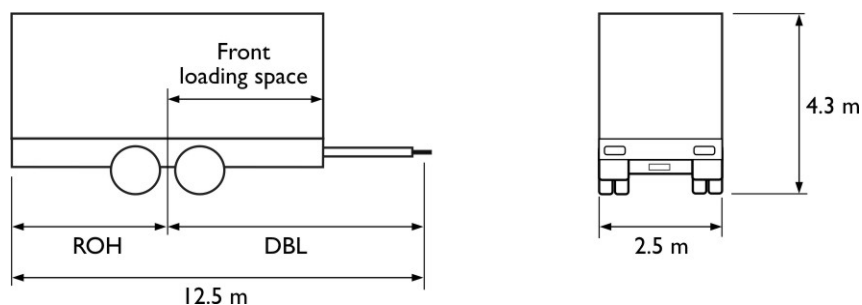

Rear overhang (ROH): No more than the length of front loading space or 3.7 metres, whichever is the lesser.

Drawbar length (DBL): Measured from the centre of the axle/axle group to the centre of the drawbar coupling pivot point with the drawbar level, must:

- Not be more than 8.5 metres.

SEMI-TRAILER, INCLUDING PLANT AND CAR CARRIER

A semi-trailer has a single axle or axle group towards the rear with a means of attachment to a prime mover that imposes some of the load on the prime mover. Semi-trailers include pole-type trailers.

The length of a semi-trailer does not include any refrigeration or other auxiliary equipment or any loading space of a reduced width at the front of the semi-trailer within the arc created by the kingpin radius.

A trailer built to carry cattle, sheep, pigs or horses on two or more partly or completely overlapping decks must not have more than 12.5 metres of its length available for the carriage of animals, measured from the inside of the front wall or door of the trailer to the inside of the rear wall or door of the trailer, with any intervening partitions disregarded.

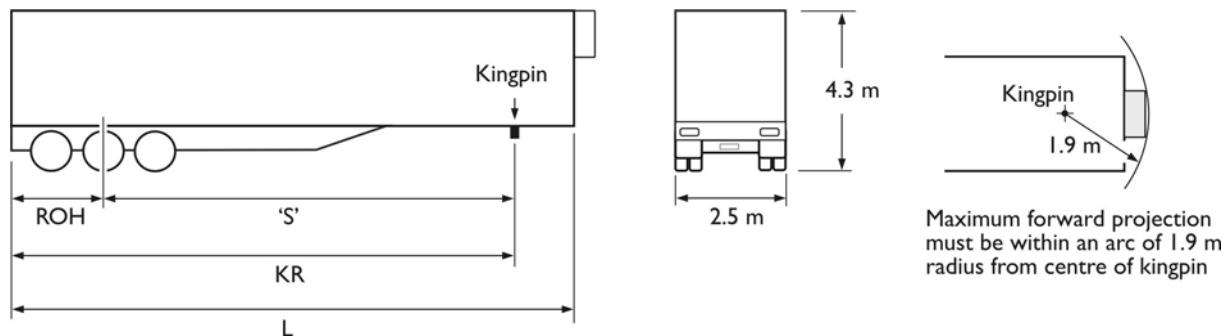

Rear overhang (ROH): 60% of 'S' dimension or 3.7 metres, whichever is the lesser.

'S' dimension*: 9.5 metres.

Kingpin to rear (KR)*: 12.3 metres.

Length (L): No specific limit, however, when combined with a prime mover, the overall combination length must not exceed 19 metres.

* Note: If a semi-trailer's point of articulation (kingpin) is adjustable longitudinally all internal dimensions (ROH, 'S' and KR) must comply with the above limits when measured at any point of kingpin adjustment.

LOW LOADER TRAILER

A low loader trailer is a 'goose-neck' type semi-trailer that has a load carrying deck (main loading space) not more than one metre above the ground over its entire length. The area above the goose-neck must not be constructed with a permanently fixed deck for the carriage of goods; however this space may be used for equipment storage eg spare wheels, tools etc. A low loader can have general access only if it also meets the statutory mass limits.

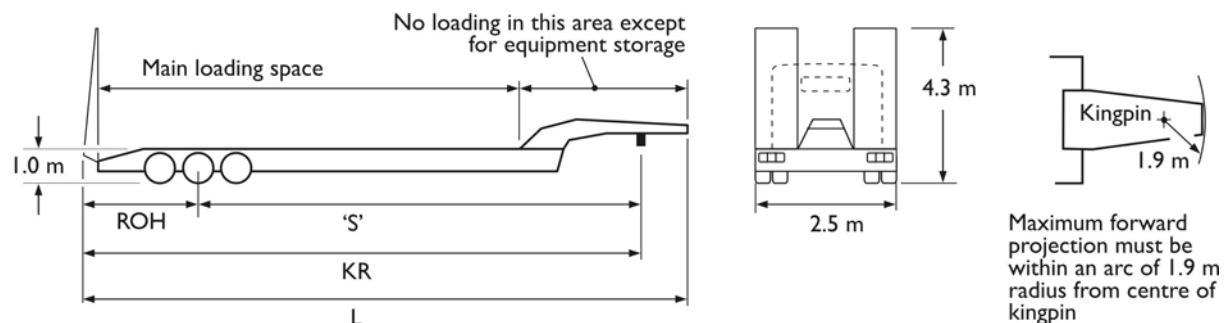

Rear overhang (ROH): 60% of 'S' dimension or 3.7 metres, whichever is the lesser.

'S' dimension: No specific limit.

Kingpin to rear (KR): No specific limit.

Length (L): No specific limit, however, when combined with a prime mover, the overall combination length must not exceed 19 metres.

B. RESTRICTED ACCESS TRAILERS

General dimensional requirements

- Extendable semi-trailers and trailers with sliding axles must conform to the applicable dimensional requirements when not carrying an indivisible load.
- A semi-trailer built for transporting livestock may exceed 13.7 metres, but not 14.63 metres, if operated in accordance with the 'Class 3 Semi-Trailer Exemption Notice 2008'.
- Plant trailers cannot have any load carrying space except for equipment essential for the operation of the trailer. For example, piping in the case of a concrete pumping unit or drills in the case of a drilling rig, and if these items make the trailer overmass or overdimension they must be removed.
- For trailers fitted with steerable and/or retractable axles see Section 6 pages 17 and 18 for rear overhang requirements.

LOW LOADER TRAILER FITTED WITH EIGHT TYRES ON EACH AXLE

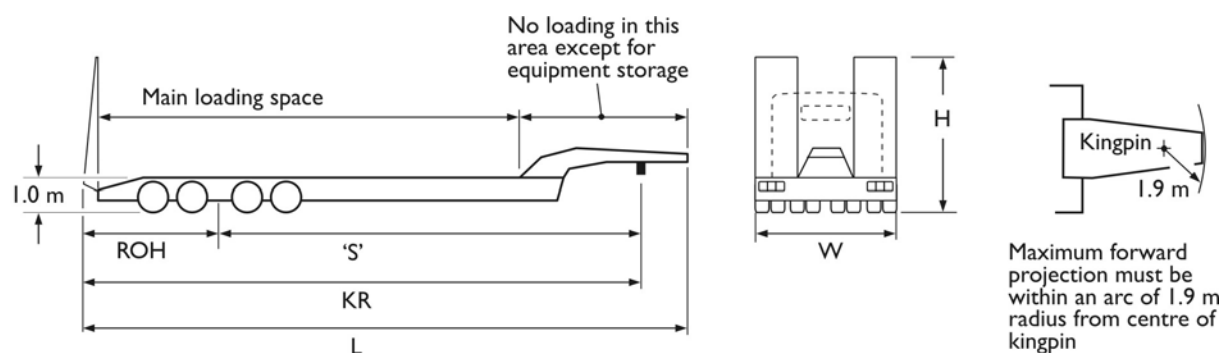

Rear overhang (ROH): 60% of 'S' dimension or 3.7 metres, whichever is the lesser.

'S' dimension: No specific limit.

Kingpin to rear (KR): No specific limit.

Length (L): No specific limit, however, when combined with a prime mover, the overall combination length must not exceed 19 metres.

Height (H): Height may exceed 4.3 metres but is limited to a maximum of 4.6 metres if operating under the '4.6 Metre High Vehicle Route Notice 2008'.

Width (W): 2.7 metres.

CLASS 3 SEMI-TRAILER UP TO 14.63 METRES

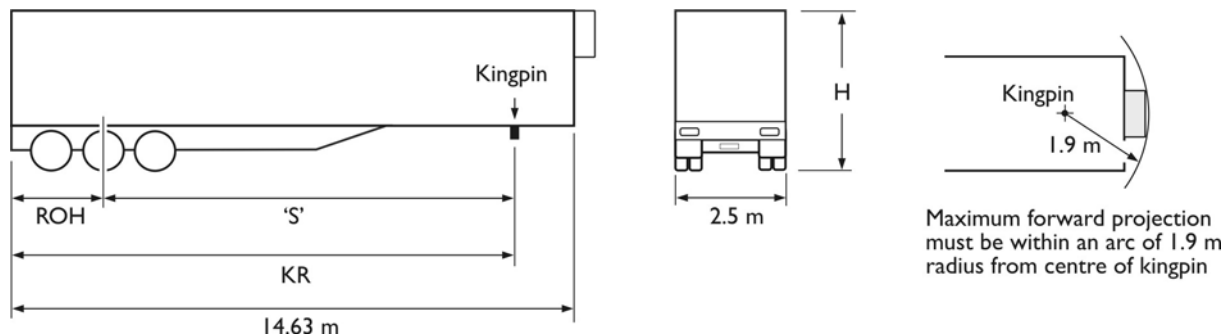

Rear overhang (ROH): 60% of 'S' dimension or 3.7 metres, whichever is the lesser.
 'S' dimension: 9.5 metres.
 Kingpin to rear (KR): No specific limit.
 Height (H): Height may exceed 4.3 metres but is limited to a maximum of 4.6 metres if operating under the '4.6 Metre High Vehicle Route Notice 2008'.

REFRIGERATED SEMI-TRAILER UP TO 14.9 METRES

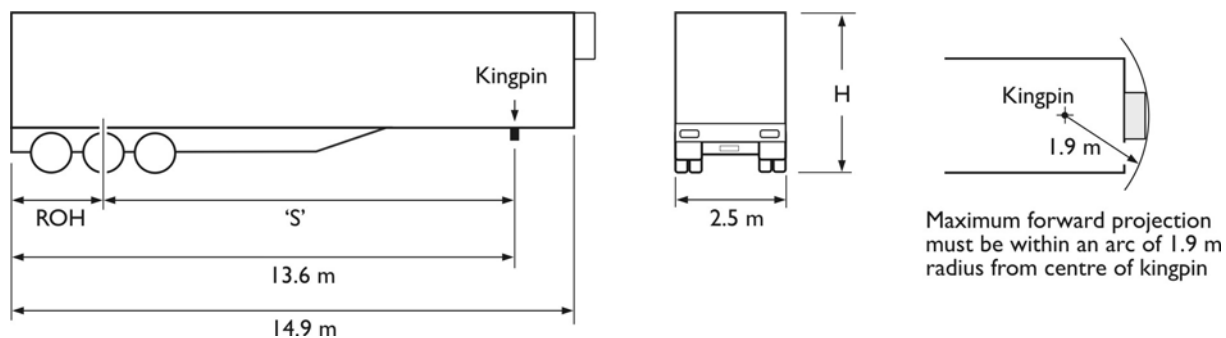

Rear overhang (ROH): 60% of 'S' dimension or 3.7 metres, whichever is the lesser.
 'S' dimension: 9.9 metres.
 Height (H): Height may exceed 4.3 metres but is limited to a maximum of 4.6 metres if operating under the '4.6 Metre High Vehicle Route Notice 2008'.

Section 4. Buses, including coaches

A. GENERAL ACCESS BUSES

BUS/COACH UP TO 12.5 METRES

A bus is a motor vehicle built mainly to carry people that seats over 9 adults, including the driver.

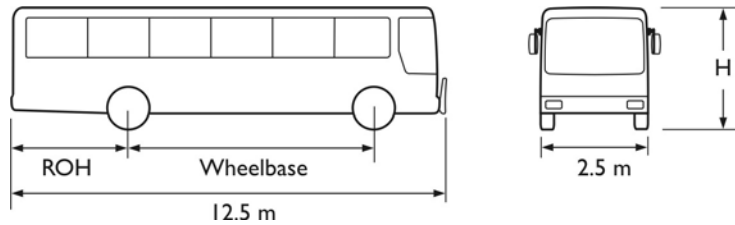

Rear overhang (ROH): 60% of the wheelbase or 3.7 metres, whichever is the lesser.

Height (H): 4.3 metres for single-deck buses; 4.4 metres for double-deck buses.

ARTICULATED ('BENDY') BUS

An articulated bus consists of at least 2 rigid sections connected to allow rotary movement and passenger access between sections.

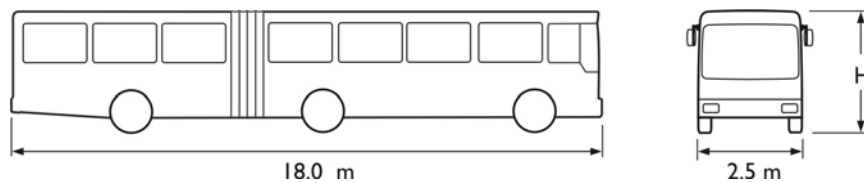

Height (H): 4.3 metres for single-deck buses; 4.4 metres for double-deck buses.

Turning circle, articulated bus

All parts, except mirrors and signalling devices, must be able to turn within a track with an inner radius of 5.3 metres and an outer radius of 12.0 metres.

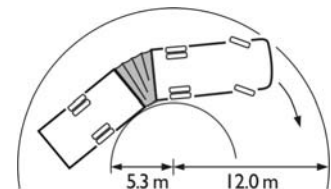

B. RESTRICTED ACCESS BUSES

CONTROLLED ACCESS BUS/COACH OVER 12.5 METRES UP TO 14.5 METRES

A controlled access bus is a bus, other than an articulated bus, that is more than 12.5 metres long. These buses may only operate under the 'Controlled Access Bus Notice 2008' on approved routes.

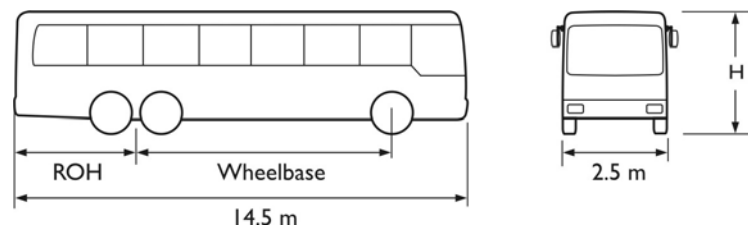

Rear overhang (ROH): 70% of the wheelbase or 4.9 metres, whichever is the lesser.

Height (H): 4.3 metres for single-deck buses; 4.4 metres for double-deck buses.

Section 5. Combinations/articulated vehicles

A. GENERAL ACCESS COMBINATIONS

The dimensions shown in this section are the maximum allowable for general access combinations/articulated vehicles as described in the Regulation.

For combinations exceeding any dimension(s) shown in this section, refer to Section 5B 'Restricted access combinations' on page 11.

Refer to Section 6 'General requirements' on pages 16 to 19 for additional notes on height and width.

TRUCK AND DOG TRAILER

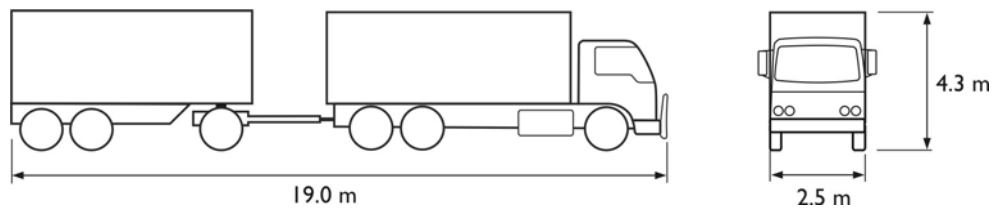

Note: If the hauling unit of a truck and dog trailer combination has a gross combination mass (GCM) in excess of 42.5 tonnes the combination is 'restricted access' and may only operate under a 'General Class 3 Truck and Dog Trailer Combination Notice 2005' – see page 11.

TRUCK AND PIG TRAILER

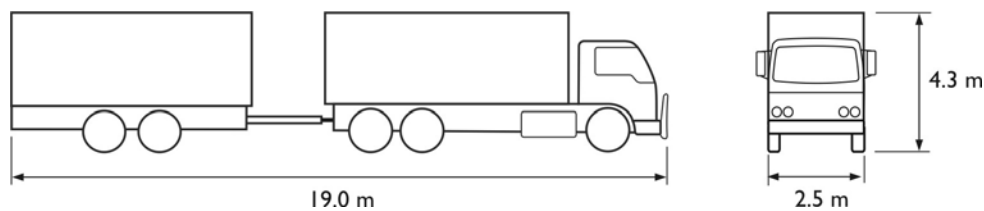

PRIME MOVER AND SEMI-TRAILER

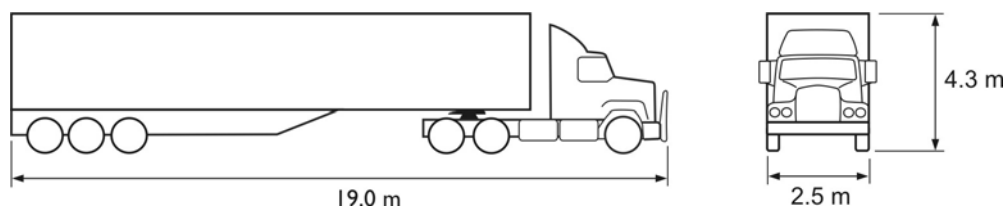

PRIME MOVER AND LOW LOADER TRAILER

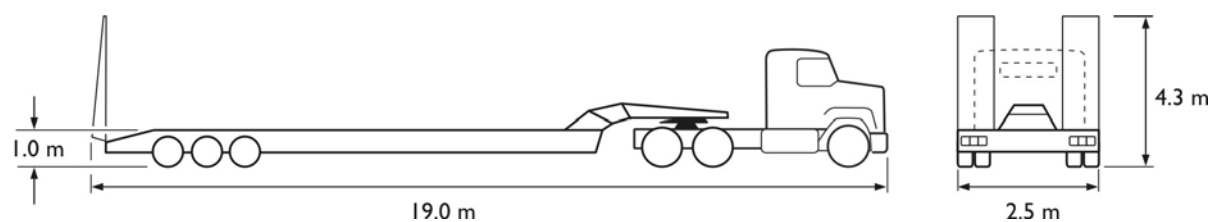

B. RESTRICTED ACCESS COMBINATIONS

Restricted access combinations/articulated vehicles include:

- Vehicle combinations longer than 19.0 metres, and some B-doubles, road trains and low loader combinations.
- Vehicles more than 4.3 metres high, other than 4.4 metre double-deck buses. Examples include livestock crates, loaded car carriers and other commodity carriers.
- Vehicles carrying indivisible loads, and operating under a 'Class 1 Oversize Permit or Notice'.
- Special Purpose Vehicles (SPVs) that exceed general access dimensions or mass limits.
- Truck and dog trailer combinations where the truck (hauling unit) has a GCM in excess of 42.5 tonnes – see below.

TRUCK AND DOG TRAILER – HAULING UNIT EXCEEDS 42.5 TONNES GCM

If the hauling unit of a truck and dog trailer combination has a GCM in excess of 42.5 tonnes the combination may operate under a 'General Class 3 Truck and Dog Trailer Combination Notice 2005' (the Notice) provided that:

- The overall dimensions of the combination do not exceed the limits for a 'general access' combination.
- The axle spacings of the combination are within the limits detailed in the Notice.
- All other requirements of the Notice are met.

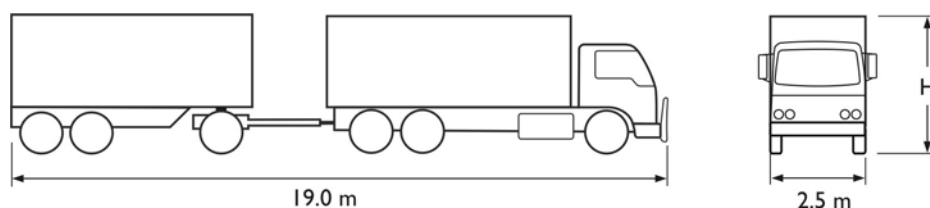

Height (H): Height may exceed 4.3 metres but is limited to a maximum of 4.6 metres if operating under the '4.6 Metre High Vehicle Route Notice 2008'.

PRIME MOVER AND LOW LOADER TRAILER – TRAILER FITTED WITH EIGHT TYRES ON EACH AXLE

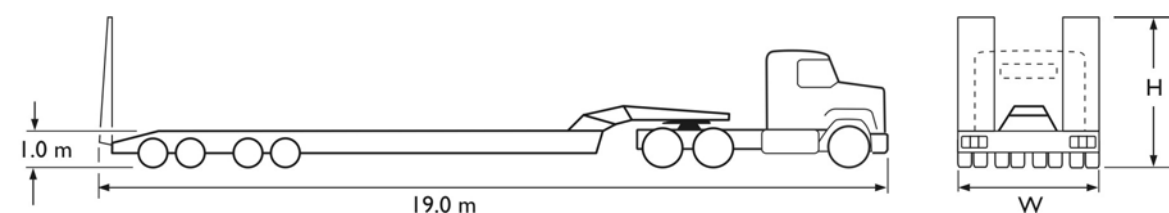

Height (H): Height may exceed 4.3 metres but is limited to a maximum of 4.6 metres if operating under the '4.6 Metre High Vehicle Route Notice 2008'.

Width (W): Prime mover 2.5 metres; trailer 2.7 metres;

CAR CARRIER – COMPRISING PRIME MOVER AND SEMI-TRAILER,

where the prime mover is not designed to carry a load over the driving compartment

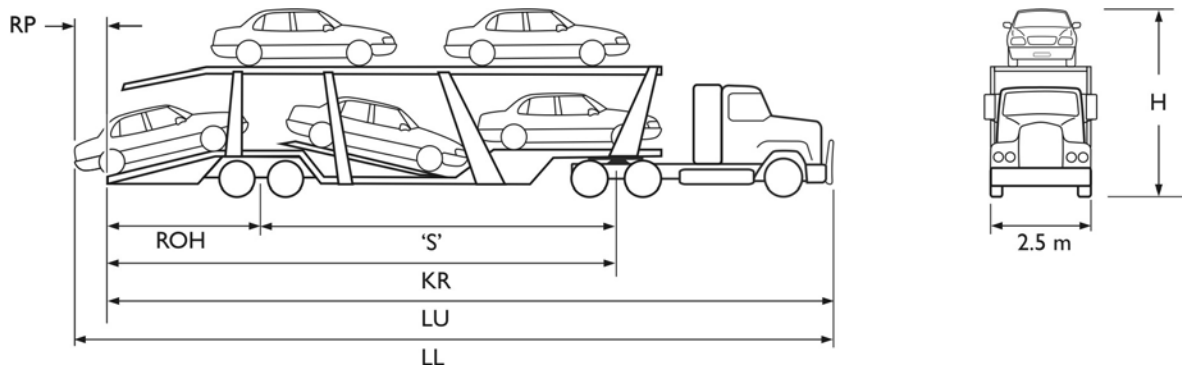

- Rear projection (RP): 1.2 metres rearward of the constructed length of the trailer, included in laden length 'LL'.
- Rear overhang (ROH): 60% of 'S' dimension or 3.7 metres, whichever is the lesser.
- 'S' dimension: 9.5 metres.
- Kingpin to rear (KR): This dimension may exceed 12.3 metres if the semi-trailer is operating under the 'Restricted Access Vehicle (Car Carrier) Exemption Notice 2005' and the 'Class 3 Semi-Trailer Exemption Notice 2008'.
- Length unladen (LU): 19.0 metres.
- Length laden (LL): 20.2 metres if operating under the 'Class 3 Semi-Trailer Exemption Notice 2008'.
- Height (H): Laden height may exceed 4.3 metres up to 4.6 metres if operating under the '4.6 Metre High Vehicle Route Notice 2008'.

CAR CARRIER – COMPRISING PRIME MOVER AND SEMI-TRAILER,

where the prime mover is designed to carry a load over the driving compartment

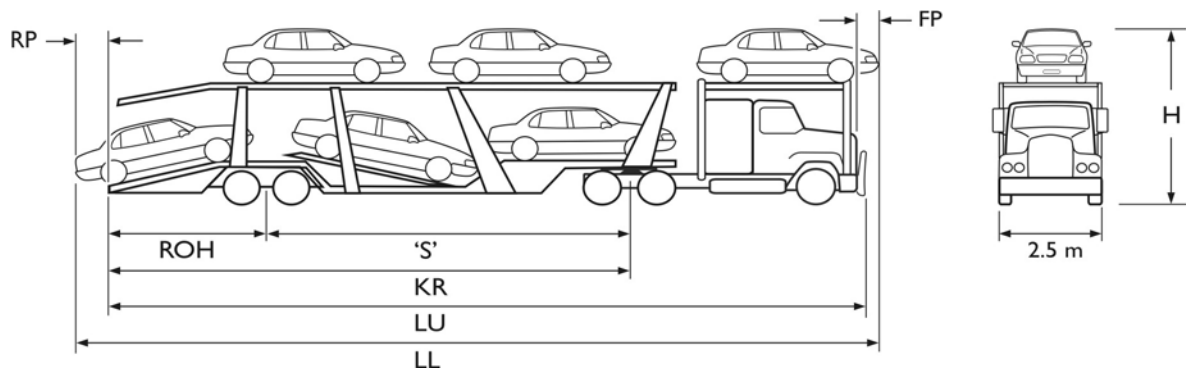

- Rear projection (RP): 1.2 metres rearward of the constructed length of the trailer, included in laden length 'LL'.
- Rear overhang (ROH): 60% of 'S' dimension or 3.7 metres, whichever is the lesser.
- 'S' dimension: 9.5 metres.
- Kingpin to rear (KR): This dimension may exceed 12.3 metres if the semi-trailer is operating under the 'Restricted Access Vehicle (Car Carrier) Exemption Notice 2005' and the 'Class 3 Semi-Trailer Exemption Notice 2008'.
- Forward projection (FP): 1.2 metres in front of headlights, included in laden length 'LL'.
- Length unladen (LU): 19.0 metres.
- Length laden (LL): 21.4 metres if operating under the 'Class 3 Semi-Trailer Exemption Notice 2008'.
- Height (H): Laden height may exceed 4.3 metres up to 4.6 metres if operating under the '4.6 Metre High Vehicle Route Notice 2008'.

CAR CARRIER – COMPRISING RIGID TRUCK AND SEMI-TRAILER,

(commonly referred to as a 'stinger' – hauling vehicle carries a load on two decks)

A car carrier combination may have an overall laden length of 25 metres if the hauling unit is designed to, when operated with or without a trailer or semi-trailer, carry a load in addition to a load over the driving compartment.

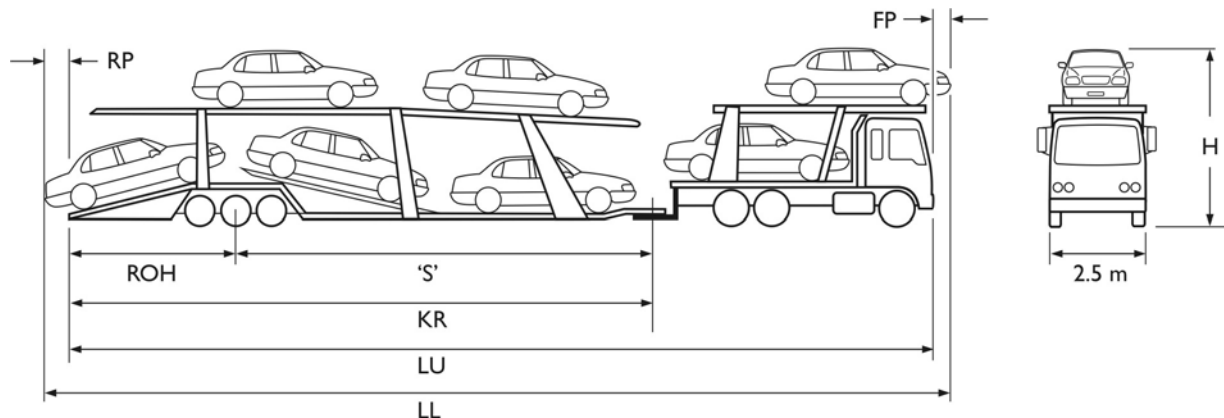

Rear projection (RP): 1.2 metres rearward of the constructed length of the trailer, included in laden length 'LL'.

Rear overhang (ROH): 60% of 'S' dimension or 3.7 metres, whichever is the lesser.

'S' dimension: 9.5 metres.

Kingpin to rear (KR): This dimension may exceed 12.3 metres if the semi-trailer is operating under the 'Class 3 Semi-Trailer Exemption Notice 2008'.

Forward projection (FP): 1.2 metres in front of headlights, included in laden length 'LL'.

Length unladen (LU): A car carrier combination with a hauling unit designed to carry a load in addition to a load above the driving compartment is exempt from the overall length requirement of 19.0 metres (Clause 3.1.8 'Restricted Access Vehicle (Car Carrier) Exemption Notice 2005').

Length laden (LL): 25 metres if operating under the 'Restricted Access Vehicle (Car Carrier) Exemption Notice 2005'.

Height (H): Laden height may exceed 4.3 metres up to a maximum limit of 4.6 metres if operating under the '4.6 Metre High Vehicle Route Notice 2008' and the 'Restricted Access Vehicle (Car Carrier) Exemption Notice 2005'.

PRIME MOVER AND SEMI-TRAILER TOWING A CONVERTER DOLLY

Operation of this combination is subject to the conditions of the 'Converter Dolly Combination Notice 2005'.

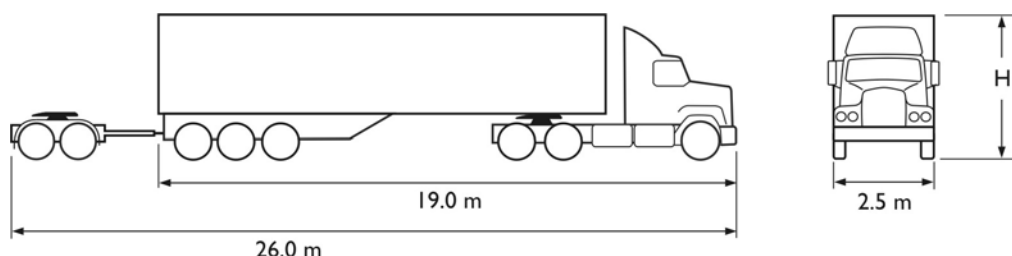

Height (H): Height may exceed 4.3 metres but is limited to a maximum of 4.6 metres if operating under the '4.6 Metre High Vehicle Route Notice 2008'.

B-DOUBLES

A B-Double is a combination consisting of a prime mover towing two semi-trailers.

In a B-Double built to carry cattle, sheep, pigs or horses, the two semi-trailers must not have more than 18.8 metres of their combined length available for the carriage of animals, with each trailer measured from the inside of the front wall or door to the inside of the rear wall or door, with any intervening partitions disregarded.

19 metre B-Double exceeding a total combination mass of 50 tonnes

This combination operates under the 'General B-Double Notice 2005'.

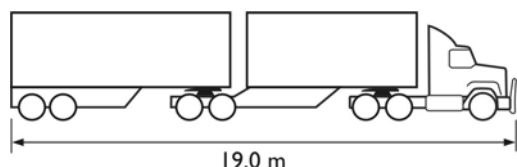

25 metre B-Double

This combination operates under the 'General B-Double Notice 2005'.

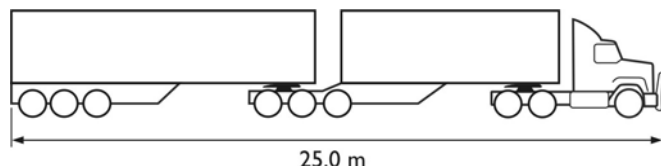

26 metre B-Double

This combination operates under the '26-metre B-Double Exemption Notice 2005'.

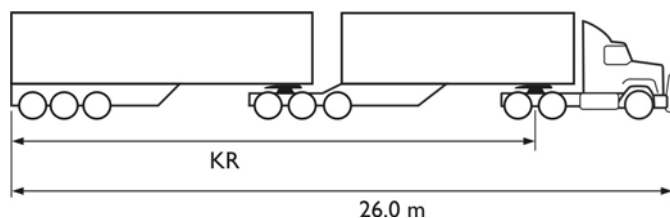

Kingpin to rear (KR): The distance from the centreline of the kingpin of the first trailer to the rear of the combination must not exceed 20.6 metres.

ROAD TRAINS

A road train is a combination, other than a B-double, consisting of a motor vehicle towing at least two trailers. All road train combinations must operate under the 'General Road Train Notice 2005'.

Prime mover, semi-trailer and dog trailer

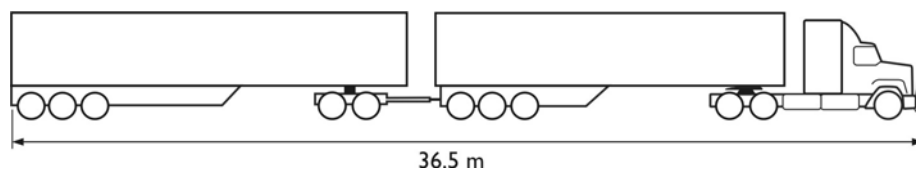

Rigid vehicle and two dog trailers

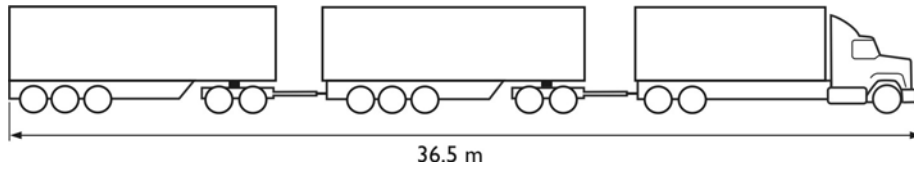

AB-Triple

A prime mover and semi-trailer combination connected, by a converter dolly, to two semi-trailers connected by a fifth wheel coupling.

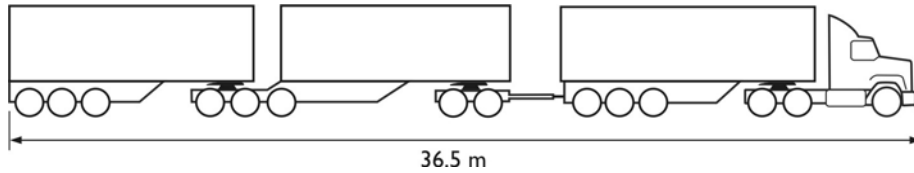

BA-Triple

A B-Double combination connected, by a converter dolly, to a semi-trailer,

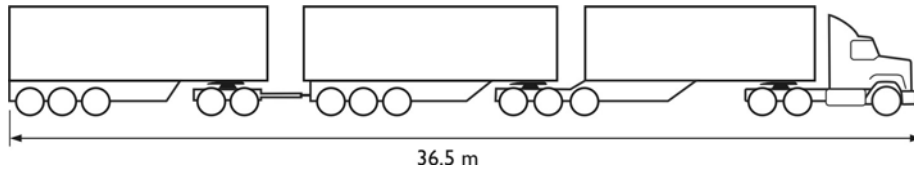

or,

a B-Double combination connected to a dog trailer.

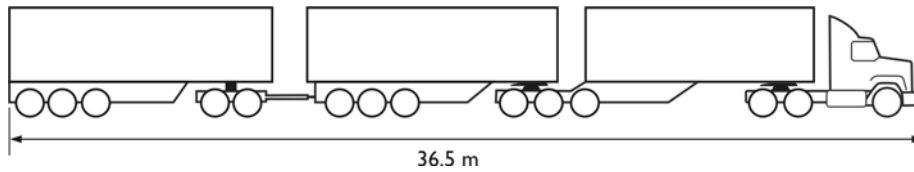

B-Triple

A prime mover towing three semi-trailers.

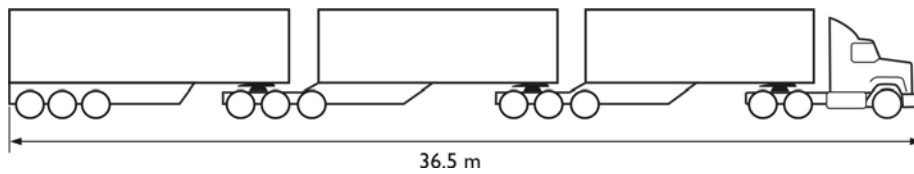

BB-Quad

A prime mover towing two B-Double semi-trailer combinations connected by a converter dolly.

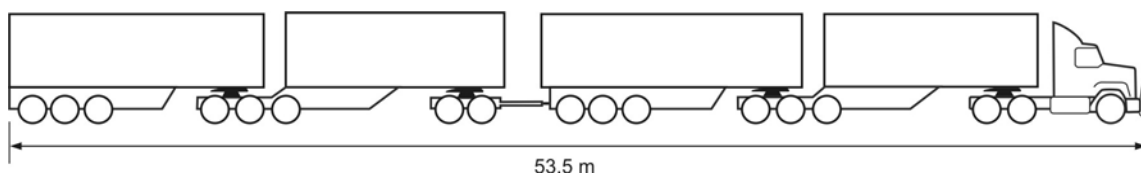

Section 6. General requirements

HEIGHT

The maximum height of a general access vehicle, laden or unladen, is 4.3 metres, except for a double-deck bus, which may be 4.4 metres.

A vehicle, other than a double-deck bus, exceeding 4.3 metres up to a maximum limit of 4.6 metres high is regarded as a restricted access vehicle and may only operate under a notice.

WIDTH

The maximum overall width of a general access vehicle, laden or unladen, is 2.5 metres. It is measured across the body and includes wheel guards, but excludes rear vision mirrors, lights, signalling devices, side mounted lights and tyre pressure monitoring systems. Any vehicle exceeding 2.5 metres in width is considered to be a restricted access vehicle and may only operate under appropriate RTA approval.

PROJECTION OF MIRRORS

Except where allowed below, the rear view mirror of a vehicle with a GVM over 3.5 tonnes must not project more than 150 mm beyond the widest part of the vehicle or combination on either side (P).

However, the rear vision mirrors may project up to 230 mm beyond the widest part of the vehicle or combination if they can fold to project not more than 150 mm beyond the widest part on either side.

For vehicles manufactured after 15 August 2006 rear vision mirrors that comply with Australian Design Rule (ADR) 14/02 by complying with ECE R46*, may protrude up to 250 mm beyond the widest part of the vehicle, where the lower edge of the mirror is less than 2 metres above the ground.

*United Nations Economic Commission for Europe Regulation No. 46

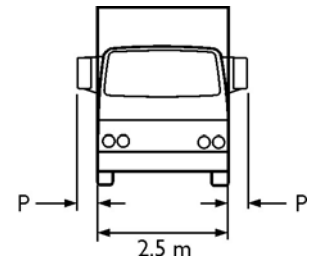

GROUND CLEARANCE

All vehicles must conform to the ground clearance requirements specified in the Regulation. This requires that ground clearance of a vehicle or combination must:

- (i) be at least 100 mm within one metre of an axle, and
- (ii) be at least one-thirtieth of the distance between centres of adjacent axles measured at the midpoint between them, and
- (iii) allow the vehicle to pass over a peak in the road with a gradient on either side of 1:15, with the wheels of one axle of the vehicle on the slope on one side of the peak and the wheels of the next axle are on the slope of the other side. This requirement applies between all axles of a vehicle or combination.

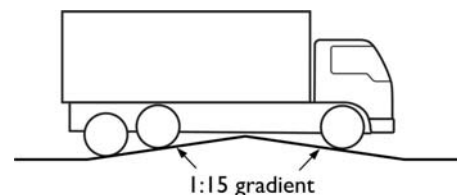
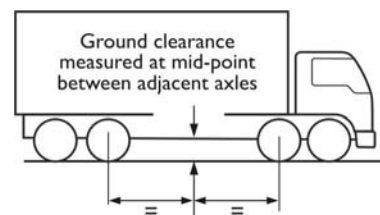

For vehicles manufactured after 16 October 2007, the following requirements also apply:

1. The running clearance for a vehicle other than a motor cycle must not be less than 100 mm.
2. Where a bus, when fully laden and at normal ride height does not meet (ii) above, a device must be fitted to enable the chassis to be lifted sufficiently to meet the ground clearance requirements.

TURNING CIRCLE (VEHICLES OTHER THAN ARTICULATED BUSES)

All vehicles must have a turning circle in either direction, such that the extreme outer edge of the tyre track at ground level does not exceed 25 metres in diameter.

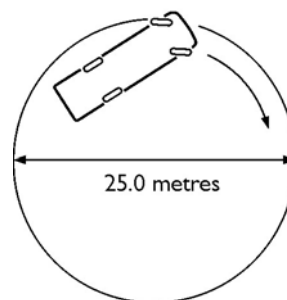

PROJECTING LOADS & EQUIPMENT

The projection of loads and equipment must comply with these limits unless the vehicle operates under a notice or permit.

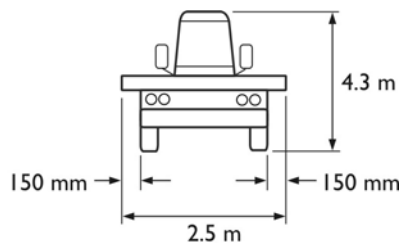
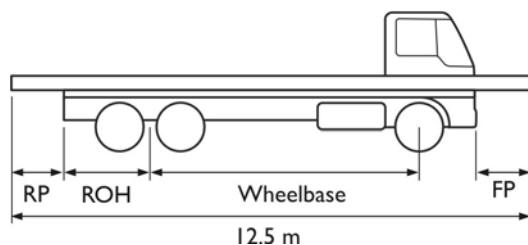

Rear projection (RP): 1.2 metres.

Rear overhang (ROH): 60% of the wheelbase or 3.7 metres, whichever is the lesser.

Forward projection (FP): 1.2 metres in front of the headlights, included in overall length (special requirements apply to mobile cranes – see page 4).

REAR OVERHANG

Rear overhang (ROH) is the distance between the ROH line and the rear of the vehicle.

The rear overhang line is determined as follows:

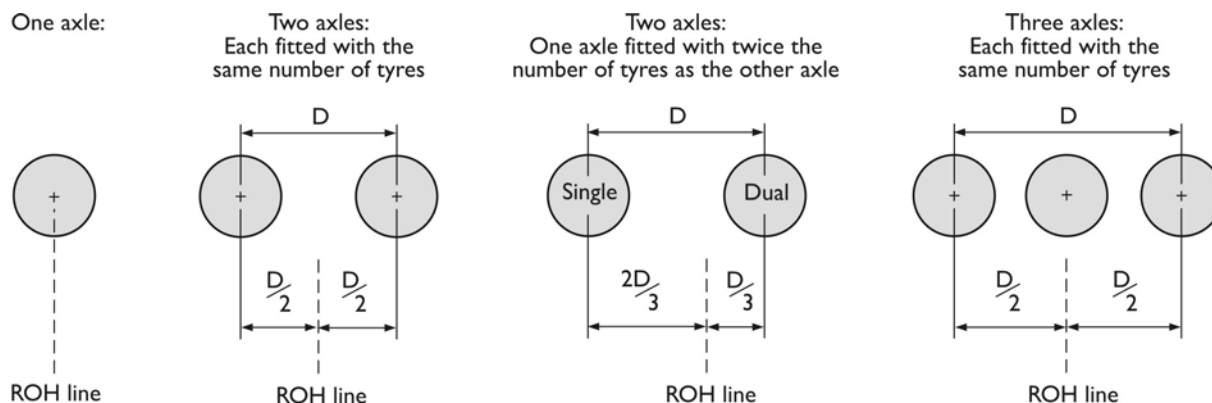

STEERABLE AXLE/S

A steerable axle in a rear axle group is ignored for the purpose of determining rear overhang, unless all axles in the group are steerable:

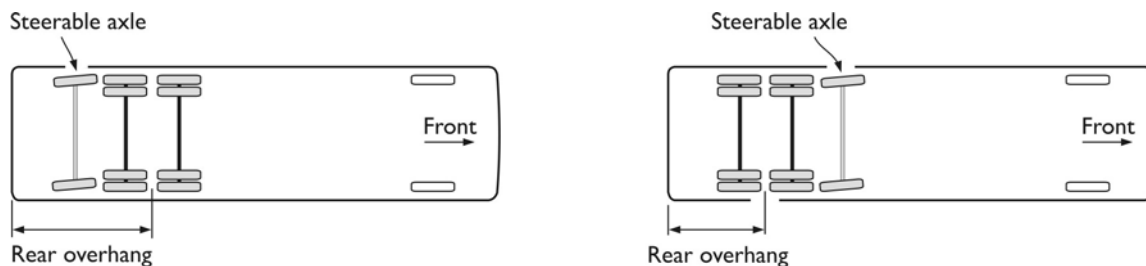

RETRACTABLE AXLE/S

A vehicle fitted with a retractable axle must, in all configurations, comply with all relevant requirements of rear overhang.

AXLE GROUPS

An axle group is a single axle group, tandem axle group, tri-axle group, quad axle group or twin steer axle group.

Rigid vehicles or prime movers are supported by two axle groups only. The wheels of the front axle group must be connected to a steering mechanism for the vehicle.

Semi-trailers have one axle or axle group towards the rear and a means of attachment to a prime mover that results in some of the load being imposed on the prime mover.

Axle groups on vehicles first registered in NSW after 28 April 1978 must be within the dimension limits shown in the following diagrams. If an axle group on any vehicle is modified after 28 April 1978 it must, after modification, also conform to these requirements.

Single axle group

A group of 2 or more axles in which the distance 'D' between centrelines is less than 1 metre.

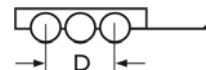

Tandem axle group

A group of 2 or more axles in which the distance 'D' between centrelines of the outermost axles is at least 1 metre, but not more than 2 metres.

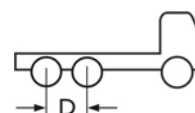

Tri-axle group

A group of 3 or more axles in which the distance 'D' between centrelines of the outermost axles is more than 2 metres, but not more than 3.2 metres.

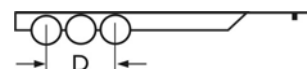

Quad-axle group

A group of 4 axles in which the distance 'D' between centrelines of the outermost axles is more than 3.2 metres, but not more than 4.9 metres.

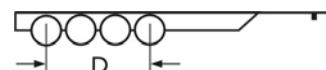

Twin steer axle group

A group of 2 axles with single tyres fitted to a motor vehicle in which the distance 'D' between centrelines of the axles is at least 1 metre, but not more than 2 metres.

Note: For a vehicle with a twin-steer axle group the front axle must be used when determining the wheelbase.

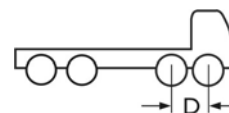

LOAD-SHARING AXLE GROUPS

For the protection of roads, tandem, tri or quad axle groups must be provided with an effective system of load-sharing. A retractable axle must also be load-sharing with other axles in the group when the retractable axle is down. A twin steer axle group may be load-sharing or non load-sharing, however lower mass limits apply if it is non load-sharing. For further information on mass and load-sharing requirements refer to the:

- Heavy Vehicle Mass, Loading and Access brochure.
- Road Transport (Vehicle Registration) Regulation 2007.
- Road Transport (Mass, Loading and Access) Regulation 2005.

Section 7. Agricultural vehicles

The maximum dimension limits for general access agricultural vehicles or combinations are:

	Height	Width	Length
Single vehicle:	4.3 metres	2.5 metres	12.5 metres
Vehicle combination:	4.3 metres	2.5 metres	19.0 metres

An agricultural vehicle or combination that exceeds any of the above dimensions is a restricted access vehicle or combination and may only operate under a notice or permit. For further information contact RTA Permits Section – see page 20 for contact details.

Section 8. Glossary

Plant means a motor vehicle that is built to operate as a machine or implement and is not capable of carrying goods or passenger by road.

Examples of plant vehicles: an agricultural machine, backhoe, bulldozer, excavator, forklift, front-end loader, grader, tractor.

Examples of vehicles that are not plant: a truck-mounted crane or truck mounted drilling rig.

Retractable axle means an axle that can be raised so that the tyres on the axle do not touch the ground.

Special Purpose Vehicle (SPV) means a motor vehicle, other than a tow truck or an agricultural vehicle, built for a purpose other than carrying a load, except for water in the case of concrete pumps and fire trucks.

Steerable axle means an axle the wheels of which are connected to a steering mechanism for the vehicle.

Trailer means a vehicle without motive power constructed to be drawn behind a motor vehicle.

Section 9. Contact details for additional information

- **Road Transport (Vehicle Registration) Regulation 2007.**
- **Road Transport (Mass, Loading and Access) Regulation 2005.**

New South Wales Government Contact Centre,
T 133 679, www.legislation.nsw.gov.au

- **Overdimension and/or overmass permits.**

RTA Permits, PO Box 97, Glen Innes NSW 2370
T 1300 656 371, F 1300 361 570, E special_permits_unit@rta.nsw.gov.au

- **Vehicle construction and registration requirements in NSW.**

RTA Technical Enquiries, PO Box 1120, Parramatta NSW 2124
T 1300 137 302, F 02 9843 3821, E tech-enq@rta.nsw.gov.au,