

## Number-plate visibility

### Purpose

This Vehicle Standards Information (VSI) No. 58 is intended to provide advice on the requirements under the provisions of the Road Transport (Vehicle Registration) Regulation 2007 (the Regulation) for positioning number-plates on vehicles in a way that ensures the number-plates' visibility. It covers all vehicles, including production models; cab-chassis to which are attached a tray or table-top body; utilities modified by fitting a tray or table-top body; heavy vehicles; and trailers.

It is also intended to provide advice to persons authorised by the Roads and Traffic Authority (RTA) to inspect vehicles under the Authorised Inspection Station Scheme, the Authorised Unregistered Vehicle Inspection Station Scheme, the Dealer Vehicle Registration Scheme and other schemes, on the mandatory requirements for the positioning and visibility of number-plates on vehicles intended to be registered in NSW.

### Background

The Regulation requires that every vehicle used on roads or road related areas in NSW complies with the applicable vehicle standards specified in Schedule 2 of the Regulation.

The position and visibility of number-plates plays an important part in helping ensure road safety. Obscured number-plates create difficulties in identifying vehicles detected committing a breach of road transport law by various camera enforcement tools. This may lead to instances of unsafe driving practices as drivers believe that they may escape penalties for such breaches. In addition, automatic number plate recognition technology allows traffic to continue to flow freely at tollways when electronic tolling devices, such as e-tags, do not work or are not fitted to a vehicle.

Consequently, there are specific requirements in Schedule 2 for the positioning and visibility of number-plates on a vehicle.

### Requirements

Clause 61(2)(b) of Schedule 2 of the Regulation requires that a number-plate is not obscured, defaced or otherwise not legible.

Clause 61(2)(c) of Schedule 2 of the Regulation requires that a number-plate must be visible at a distance of 20 metres from it and within all the areas described by an arc extending at an angle 45° above the top of the number-plate and 45° forward of its edges. This is depicted on following pages 2 and 3 in Figure 1 for light vehicles, Figure 2 for trailers, Figure 3 for motorcycles and Figure 4 for heavy vehicles.

#### For further enquiries

RTA Technical Enquiries, PO Box 1120, Parramatta NSW 2124

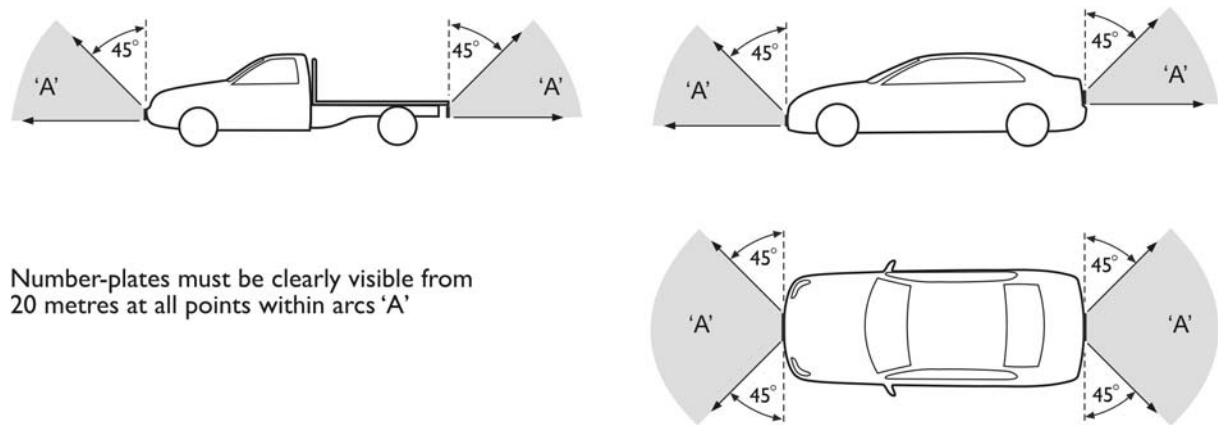
**T** 1300 137 302 | **F** 02 9843 3821 | **E** [tech-enq@rta.nsw.gov.au](mailto:tech-enq@rta.nsw.gov.au)

**[www.rta.nsw.gov.au](http://www.rta.nsw.gov.au)**

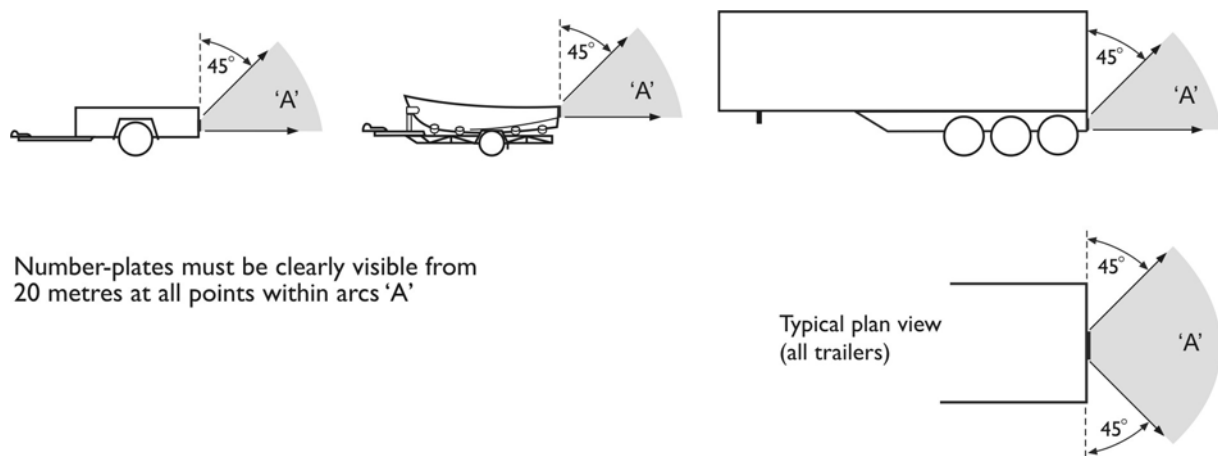
Unless exempted, all characters on the number-plate, as fitted, must be fully visible when viewed from all positions within the areas described above. They must not be obscured, even partly, by the body of the vehicle, any load that it is carrying, number-plate holders or covers, or any attachment, including tow couplings (ie tow bars, hitches, etc) or spare wheels.

Note: The requirements for number-plates for vehicles carrying bike racks are given in VSI 10 *Carrying bicycles on motor vehicles*.

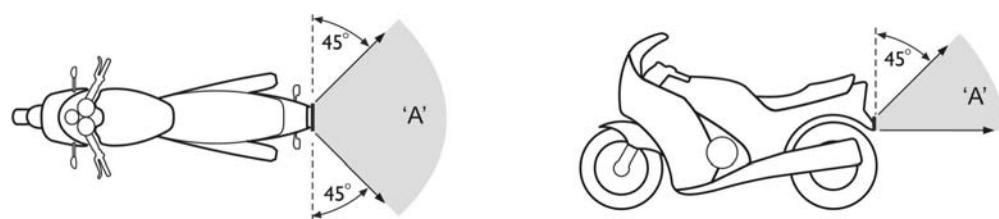
**FIGURE 1: NUMBER-PLATE VISIBILITY – LIGHT VEHICLE EXAMPLES**



**FIGURE 2: NUMBER-PLATE VISIBILITY – TRAILER EXAMPLES**

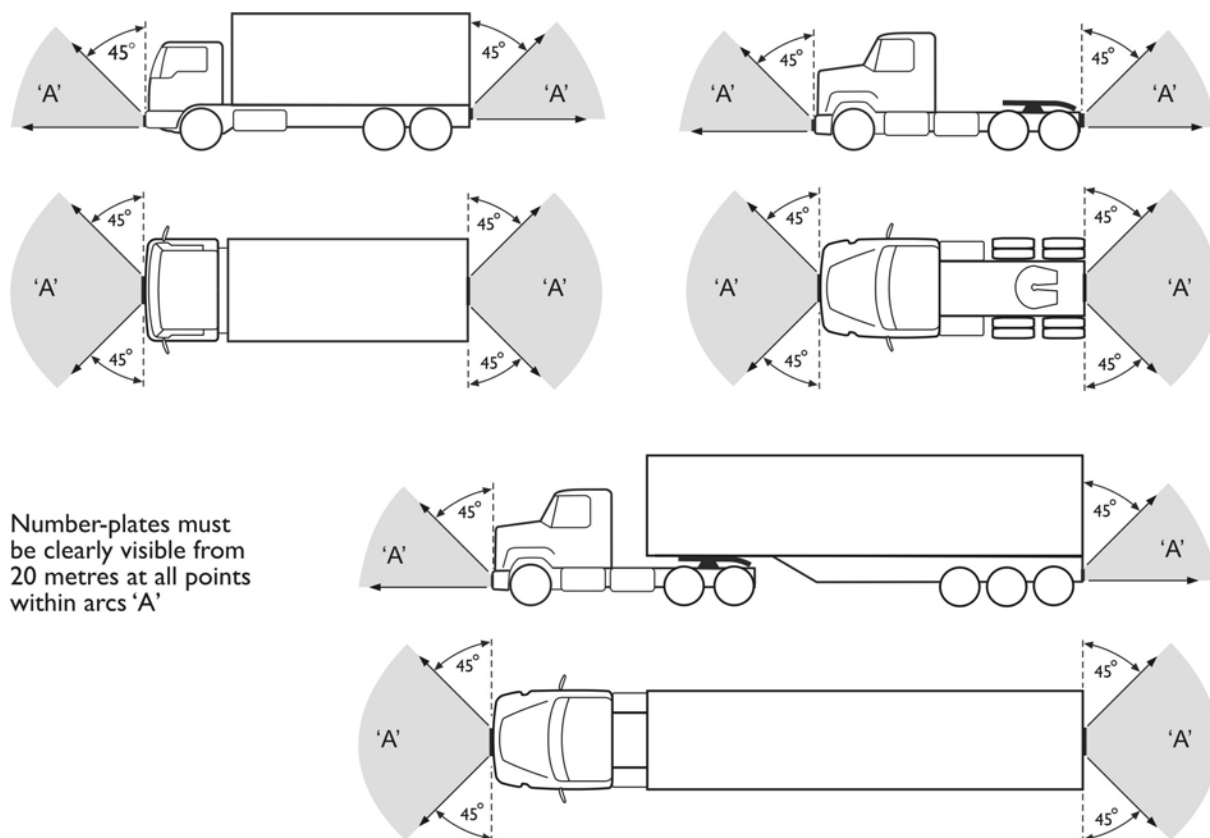


**FIGURE 3: NUMBER-PLATE VISIBILITY – MOTORCYCLE EXAMPLE**



Number-plates must be clearly visible from 20 metres at all points within arcs 'A'

FIGURE 4: NUMBER-PLATE VISIBILITY – HEAVY VEHICLE EXAMPLES



## Exempted vehicles

The RTA has provided an exemption to the number-plate requirements of Schedule 2 in limited instances. Under the exemption, a vehicle fitted with an identification plate or label (sometimes called a 'compliance plate') issued by the [Commonwealth] Department of Infrastructure and Transport (DIT) is not subject to the requirements if:

- a) due to the original construction of the vehicle it is not practicable to comply with the requirements, and
- b) the number-plate is affixed in a manner that complies so far as practicable with the requirements.

The exemption applies only to the original design and construction of a vehicle that is fitted with an identification plate or label issued by the DIT. It does not extend to a body or tray top subsequently fitted to the vehicle, or obstructions caused by the fitting of temporary equipment such as tow bars or additional spare tyres.

## Registration and enforcement

A vehicle with a number-plate positioned contrary to the requirements specified in this VSI No. 58 may not be registered in NSW. In addition, the registered operator of a vehicle found to have a number-plate positioned contrary to these requirements, or obscured by equipment or a load, during an RTA inspection or on-road police inspection, may be issued with a defect notice.