



www.rta.nsw.gov.au/dvpr/vss.htm

Movement of Grain Auger Trailers in New South Wales

Introduction

Augers in combination with their towing vehicles usually exceed the dimension limits for standard vehicle combinations. If these limits are exceeded an auger and vehicle combination may be permitted to operate on either a general or specific oversize permit for agricultural vehicles.

The purpose of this information sheet is to set out the obligations for the legal movement of grain auger trailer combinations in New South Wales. It should be noted that the dimensions shown in this information sheet supersede the dimensions for augers appearing in the current "Operators Guide to Oversize and Overmass Vehicle Movements which incorporates the Handbook for the movement of Overdimension Vehicles operating under the General Permit Scheme".

Public road travel by auger combinations can be broken up into three categories. These categories are:

- **General Access**

Auger combinations that are within standard dimension limits have general access to the road network. An oversize permit is not required for travel.

- **General Oversize Permit (Agricultural)**

Auger combinations which exceed standard dimension limits will need either a general oversize permit or a specific oversize permit, depending on their dimensions. See the table on page 3 which sets out the special dimension limits for augers.

Augers eligible for general permit travel are required to comply with the general permit conditions for agricultural combinations as set out in the permits handbook (the Operators Guide to Oversize and Overmass Vehicle Movements). Operators are required to carry a copy of the permit in the vehicle, comply with its requirements and produce it to authorised officers if required.

Copies of this handbook are available from your local motor registry.

- **Specific Oversize Permit**

Auger combinations which exceed general permit dimensions are required to apply for a specific permit from the RTA Permits Unit. Specific permits contain stricter travel conditions than for general permit travel due to the size of the combination.

If the rear overhang of an auger combination exceeds the allowed percentage of overall length as per the table below, an alternative means of transporting an auger can be required before a specific permit can be issued.

Contact details for the Permits Unit are on page 3 of this publication.

Auger Combination Dimension Limits

The following dimension limits and permit types apply to travel by auger combinations:

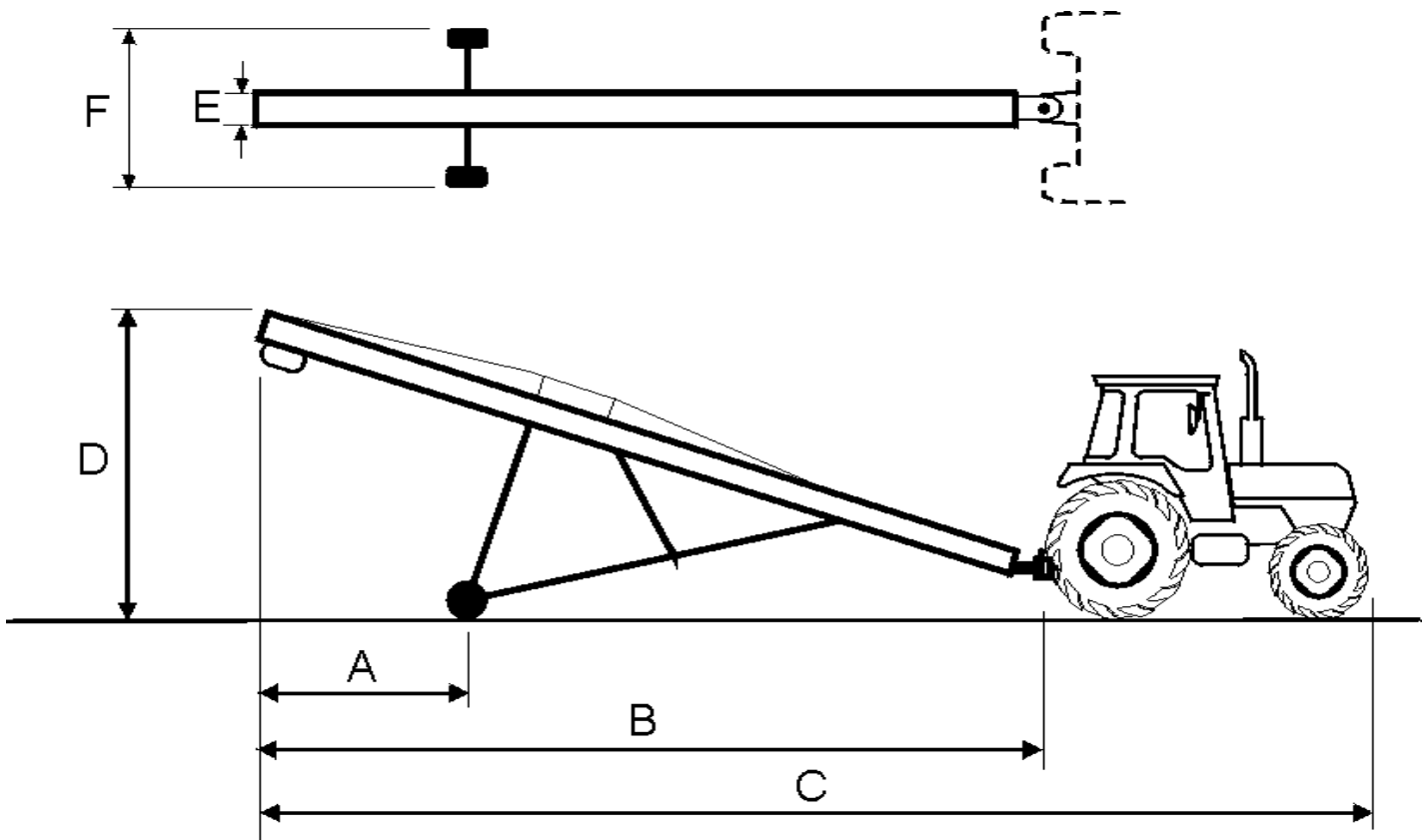

Dimension	A (note 1)	B	C	D	E	F
General Access	(up to) 3.7 m	(up to) 12.5 m	(up to) 19.0 m	(up to) 4.3 m	N/A	(up to) 2.5 m
General Permit (note 2)	(up to) 8.0 m (Metro and Eastern Zone) 9.0 m (Western Zone)	(up to) 19.0 m	(up to) 25.0 m	(up to) 4.3 m	(up to) 0.75 m	(up to) 5.0 m (Metro and Eastern Zone) 6.0 m (Western Zone)
Specific Permit	(over) 8.0 m (Metro and Eastern Zone) 9.0 m (Western Zone)	(over) 19.0 m	(over) 25.0 m	(over) 4.3 m	(over) 0.75 m	(over) 5.0 m (Metro and Eastern Zone) 6.0 m (Western Zone)

Notes: (1) The auger rear overhang (dimension A) must not exceed 50% of the augers overall length (dimension B) for General and Specific permit applications.

(2) Where dimensions for the “General Permit” are exceeded, an application for a “Specific Permit” must be sent to the Roads and Traffic Authority’s Permits Unit for assessment. As a general rule Specific Permits may be issued for periods of up to 12 months for point-to point travel or travel within a 25 km radius, or 1 month journey permits may be issued for larger augers.

Permits and information on their nature and conditions of permit travel may be obtained by contacting the:

Permits Unit
Roads and Traffic Authority
Ground Floor, Centennial Plaza
260 Elizabeth St
SURRY HILLS NSW 2010

Telephone No. (02) 9218 6221
or 1 800 677 583 if calling from
outside the Sydney Metropolitan area
Fax No. (02) 9218 6564

Further Information

RTA Blacktown:

Vehicle Regulation Unit
Level 1, 85 Flushcombe Road
PO Box 558
BLACKTOWN NSW 2148

Tel: (02) 9830 5555
Fax: (02) 9831 0913

RTA Wollongong:

Vehicle Regulation Unit
104 Market Street
PO Box 5398
WOLLONGONG NSW 2500

Tel: (02) 4226 7007
Fax: (02) 4225 8844

RTA Newcastle:

Vehicle Regulation Unit
59 Darby Street
Locked Bag 30
NEWCASTLE NSW 2300

Tel: 1 800 049 920
or (02) 4924 0240
Fax: (02) 4924 0659

RTA Parkes:

Vehicle Regulation Unit
PO Box 334
PARKES NSW 2870

Tel: 1 800 809 388
Fax: (02) 6862 8496