



Natural Gas Fuel Systems for Motor Vehicles

Introduction

Compressed natural gas (CNG), also called natural gas for vehicles (NGV) is an alternative fuel that is suitable for automotive use. NGV has been available for some time now but it has only recently started to become widely used.

Some important differences about NGV and LPG systems

Natural gas should not be confused with liquid petroleum gas (LPG). NGV is stored at much higher pressures than LPG. New NGV systems are designed to store the gas at a pressure of 20MPa which is about 20 times greater than LPG and about 100 times the air pressure commonly used in passenger car tyres. NGV system components are specially designed to operate at this higher pressure. **NGV systems must never be refuelled with LPG.**

NGV is lighter than air and in the case of leakage, the gas will dissipate into the atmosphere. Liquid petroleum gas (LPG) on the other hand is heavier than air and will stay near the ground or in pockets in the vehicle structure until it is carried away by air currents.

Who can install NGV systems?

NGV installations must comply with a code published by Standards Australia (known as *Natural Gas Fuel Systems for Vehicle Engines* , AS2739-1992).

Work on an NGV installation can only be carried out by a business licensed by the Motor Vehicle Repair Industry Council (MVRIC). The required licence is for "Natural Gas Mechanic" issued under the Motor Vehicle Repairs Act, 1980. The work for which the licence is needed includes installing a NGV system to a motor vehicle or repairing or adjusting any NGV equipment that has already been fitted to a vehicle. The tradesperson performing the installation, repair or service must hold a tradesman's certificate as a "Natural Gas Mechanic", issued by the MVRIC.

Before you allow anybody to convert your vehicle to NGV operation or to do any work on the gas fuel system in your vehicle if it already runs on NGV, you should make sure that the business has a Natural Gas Mechanic's licence.

In the case of commercial vehicle operators who carry out work only on vehicles owned by themselves or their company, a repairer's licence is not required. However, the tradesperson performing the work must hold a "Natural Gas Mechanic" tradesmans certificate.

After a NGV installation is fitted the installer must give the owner of the vehicle a certificate of compliance showing that the installation is in safe working order. An example of a certificate of compliance is shown below. The certificate must be completed in full by the installer.

DANGEROUS GOODS (GAS INSTALLATIONS) REGULATION, 1982
WorkCover Authority (NSW)
CERTIFICATE OF COMPLIANCE - AUTOGAS INSTALLATION

Certificate No.....

This certifies that.....the holder
(NAME)

of..... Licence No. 46/
(TYPE OF TRADESMAN'S CERTIFICATE IE. LPG/CNG)

employed by..... Repairers No. 44/
(NAME OF REPAIRER)

has tested an Autogas (LPG/CNG)* installation fitted to a
 Vehicle*/Vessel*/Machine*

Type (Vehicle/Machine)

Make & Model

Engine No.Reg'd No.

Chassis No.

Owned by

Address

..... Postcode

and is satisfied that the installation (together with the gas containers and gas metering devices connected to it) are in safe working order.

The following gas containers are connected to the installation:-

Type	Capacity	WC	Serial No.
	WC	

Date of installation/test*.....Signed.....

***delete where not applicable** ©

Figure 1 - Certificate of compliance

What do NGV compliance plates look like?

Vehicles with NGV systems installed by a licensed NGV installer will be fitted with a natural gas compliance plate like the example shown below. The NGV compliance plate is normally attached near the vehicle's original ADR compliance plate or adjacent to the pressure vessel which is usually installed in the boot of passenger cars.

WorkCover Authority (NSW) <small>This autogas installation is designed for use with</small>	
NATURAL GAS	
CERTIFICATE OF COMPLIANCE No.:	_____
TESTED BY: <u>46/</u> _____	(CERTIFICATE No.)
REPAIRER: <u>44/</u> _____	(LICENCE No.)
DATE OF TEST:	_____
CHASSIS No.:	_____
ENGINE No.:	_____

Figure 2 NGV compliance plate

Note: Plates which show "Department of Industrial Relations" instead of "WorkCover Authority (NSW)" are acceptable.

What other NGV identification signs are required?

Every vehicle converted to run on NGV must also carry affixed to the front and rear number plates, a red retro-reflective label as shown in the samples below. These labels are available from all licensed NGV installers.

The labels must not be less than 25mm square and the letters NGV or CNG are to be at least 6mm in height.



NGV vehicles must also be fitted with a refuelling information plate near the filler connection which provides the information shown below. This plate is marked with the maximum filling pressure for the system. Most new NGV installations have a maximum filling pressure of 20MPa, however, some earlier conversions had a maximum filling pressure of only 16.5MPa.

NGV	
MAX. FILLING PRESS	MPa at°C
TOTAL CAPACITY	LITRES
CONTAINER I.D. No	
NEXT RETEST	

Figure 3 Typical refuelling information plate

NGV fuel systems

Petrol vehicles that are converted to operate on NGV can be equipped to run alternatively on NGV or petrol or on NGV only. Some diesel fuelled vehicles may be equipped to run on a mixture of NGV and diesel.

Equipment for NGV vehicles

The six main component parts fitted to the vehicle are:

- The filler connection which incorporates a non return valve.
- The NGV storage cylinder together with a cylinder valve which incorporates a fusible plug.
- A first stage regulator to reduce the pressure from 20MPa to approximately 0.7MPa.
- A vacuum operated NGV fuel lock-off valve which prevents the flow of NGV fuel when the engine stops.
- A second stage regulator which further reduces the pressure.
- An air/gas mixer that measures air flow and meters the flow of gas into the engine.

**Figure 4:
Equipment**

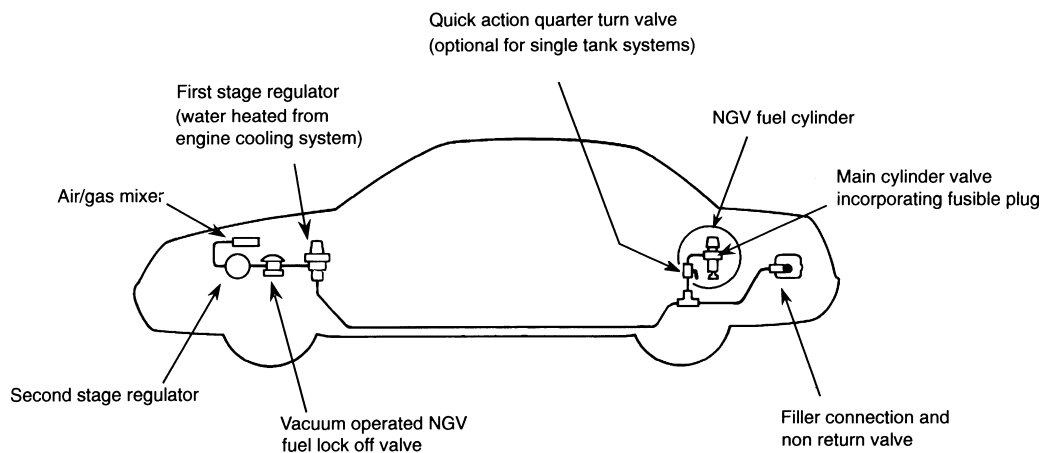

NGV fuel cylinders

The NGV fuel cylinder is a tested pressure vessel which is designed and constructed in accordance with strict Australian Standards. During manufacture it is subjected to controlled heat treatment. Therefore it is imperative that no welding, soldering, brazing or heating of the cylinder takes place after the manufacture of the vessel.

All cylinders must be securely and permanently affixed and must be capable of being filled in that position.

Some NGV fuel cylinders are constructed using fibreglass reinforced plastic (FRP) wrapped around the outside of the steel cylinder. This type of construction allows for a lighter NGV cylinder but it is important that the FRP layer is not damaged as this provides part of the cylinder's strength.

All-steel cylinders and FRP reinforced steel cylinders must be inspected periodically. All-steel cylinders may continue to be used for as long as these inspections show that the cylinder remains sound, however FRP wrapped steel cylinders must be replaced after 15 years of use.

What are my obligations regarding periodic inspections of NGV cylinders?

The Dangerous Goods Act which is administered by the WorkCover Authority (NSW) requires NGV cylinders to be periodically inspected and marked indicating the date on which the tanks were last inspected. In the case of all-steel cylinders, these inspections must be conducted every five (5) years and three (3) years in the case of fibreglass reinforced plastic (FRP) wrapped steel cylinders. NGV

cylinders are usually marked with a yellow sticker which indicates the date when the next inspection is due. This date is also marked on the refuelling information plate which is required to be fitted near the fill point. Owners must ensure that the NGV cylinder fitted to their vehicle is inspected before the required re-test date for the cylinders.

When the inspection of a NGV cylinder is required, the owner should enlist the services of an Approved Gas Cylinder Testing Station (as approved by Standards Australia).

What are the registration requirements for vehicles fitted with Natural Gas?

New converted vehicles

When a vehicle is newly converted by a licensed NGV installer you must notify the RTA so that registration records can be amended. An *Adjustment of Records form 1021* should be completed. The certificate of compliance for the NGV installation should also be presented to assist the RTA to determine that the installation has been done by a licensed person.

NGV Vehicles already in service

When renewal of registration is due and the annual Safety Check is required, most existing NGV vehicles will either:

- a) Go to an Authorised Safety Check Inspection Station which has an examiner who is licensed to check natural gas fuelled vehicles.
OR
- b) Go to an Authorised Safety Check Inspection Station which has an examiner who is licensed to examine LPG fuelled vehicles.

As part of the annual Safety Check, the authorised examiner will do the following:

- a) check for the presence of the following vehicle markings:
 - NGV compliance plate;
 - NGV refuelling information plate;
 - NGV number plate labels.
- b) check that the NGV cylinder is not due for retest;
- c) check that the main cylinder valve and any other manual valves can be opened and closed;
- d) check that there are no signs of leakage from the system;
- e) check that the automatic fuel lock-off valve is fitted and functions correctly;
- f) for dual fuel vehicles, check that the alternative fuel selector switch is present and functions correctly;
- g) inspect the condition and mounting of all components of the system for damage, deterioration, abrasion, corrosion, cracks or metal fatigue and looseness in mountings;
- h) check that there is a captive refuelling connection dust cap and there are no signs of damage to the connection;
- i) check that the NGV cylinder has the required minimum ground clearance ie. 200mm for light vehicles OR 300mm for heavy vehicles (over 4.5 tonne unladen mass or having a chassis ground clearance exceeding 610mm at the rear).

Details of the nearest AIS which may inspect vehicles fuelled by NGV may be obtained by contacting RTA Technical Enquiries on the telephone numbers listed below:

SYDNEY (Blacktown) : (02) 9830 5555
WOLLONGONG : (02) 4226 7007

CHARLESTOWN : (02) 4940 5555
PARKES 1 800 809 388

Interstate vehicles fitted with LPG fuel systems

Any NGV fuelled vehicle registered in another State or Territory and submitted for registration in NSW may be accepted provided that:-

- a) a metal plate is attached in a prominent position near the installation, showing the following details:
- statement that the installation complies with Australian Standard AS2739 Natural gas fuel systems for vehicle engines, and
 - the date the installation was commissioned, and
 - the State or Territory where the installation took place, and
 - identification number of the suitably qualified person responsible for the installation.

Note: If no such plate is attached, the owner or operator of the vehicle will be required to take it to a licensed NGV installer who will test and (if required) modify the system and attach the approved identification plate.

- b) The installation must also pass a Safety Check Inspection conducted by an LPG or NGV Authorised Examiner at an AIS Station.

What are the pollution control equipment requirements for NGV vehicles?

Usually, no re-testing of engine exhaust emissions is required for NGV conversions if a vehicle is intended to operate primarily on NGV. However, in the case of vehicles which are capable of using either petrol or NGV, any pollution control equipment fitted by the original vehicle manufacturer must be retained on the vehicle and must be fully functional when the vehicle is operating on petrol.

What if the vehicle structure needs to be modified?

Where the installation of NGV equipment involves major structural alterations such as removal of portions of a subframe, floorpan or roof support pillar, it is possible that the vehicle's structural strength may be downgraded. In such cases, it is recommended that an Engineering Signatory experienced in chassis/body design be consulted to ensure that the modified vehicle is safe. Vehicle Standards Information Sheet No. 15 lists persons available for consultation. Generally, the NGV installer will attend to the approval of structural alterations.

FURTHER INFORMATION

RTA Blacktown:

Vehicle Regulation Unit
Level 1, 85 Flushcombe Road
PO Box 558
BLACKTOWN NSW 2148

Tel: (02) 9830 5555
Fax: (02) 9831 0913

RTA Wollongong:

Vehicle Regulation Unit
104 Market Street
PO Box 5398
WOLLONGONG NSW 2500

Tel: (02) 4226 7007
Fax: (02) 4225 8844

RTA Charlestown:

Vehicle Regulation Unit
Cnr Pacific Hwy & Frederick St
PO Box 585
CHARLESTOWN NSW 2290

Tel: 1 800 049 920
or (02) 4940 5555
Fax: (02) 4921 0827

RTA Parkes:

Vehicle Regulation Unit
PO Box 334
PARKES NSW 2870

Tel: 1 800 809 388
Fax: (02) 6862 8496

Licensing of Installers, Location of Installers:

Motor Vehicle Repair Industry Council
239 Great North Road
PO Box 213
FIVE DOCK NSW 2046
Tel: (02) 9712 2200

Approval of Equipment

WorkCover Authority
400 Kent Street
SYDNEY NSW 2000
Tel: (02) 9370 5000