

Road Transport (General) Act 2005

Exemption Notice made under the Road Transport (Mass, Loading and Access) Regulation 2005, and the Road Transport (Vehicle Registration) Regulation 1998

I, Les Wielinga, Chief Executive of the Roads and Traffic Authority, pursuant to Clause 10 of Schedule 4 to the *Road Transport (Vehicle Registration) Regulation 1998*, and Clause 12 of the *Road Transport (Mass, Loading and Access) Regulation 2005*, do, by this Notice, exempt vehicles that are described in clause 2.1 of the Schedule to this Notice from the dimensions, as specified in the Schedule to this Notice, set out in Schedule 4 to the *Road Transport (Vehicle Registration) Regulation 1998*, and the dimension limits in Schedule 1 and clause 24 of Schedule 2 to the *Road Transport (Mass, Loading and Access) Regulation 2005*, subject to the conditions and requirements set out in the Schedule.

Les Wielinga
Chief Executive
Roads and Traffic Authority

SCHEDULE

PART 1 – PRELIMINARY

1.1 Citation

This Notice may be cited as the Grain Auger Combination Exemption Notice 2007.

1.2 Commencement

This Notice takes effect on 1 August 2007.

1.3 Limitation

This Notice continues to have effect until 30 September 2010 unless it is amended or repealed earlier.

1.4 Repeal

This Notice repeals the Grain Auger Combination Exemption Notice 2003.

1.5 Interpretation

Unless stated otherwise, words and expressions used in this Notice have the same meanings as those set out in the Dictionary forming part of the *Road Transport (Mass, Loading and Access) Regulation 2005*.

A note in the text of this Notice does not form part of this Notice.

PART 2 – APPLICATION, OPERATING CONDITIONS AND REQUIREMENTS

2.1 Application

2.1.1 This Notice applies provided that a vehicle, of the kind described in 2.1.2, is operated in accordance with the relevant provisions of the General Class 1 Oversize (Agricultural Vehicle) Notice 2007.

2.1.2 This Notice applies to a grain auger trailer in combination with a towing motor vehicle where a dimension for the trailer or the combination exceeds a dimension limit specified in clauses 70, 73 (1) (d), 74 (4) and 75 (2) of Schedule 4 to the *Road Transport (Vehicle Registration) Regulation 1998*, or the dimension limits specified in Schedule 1 and clause 24 of Schedule 2 to the *Road Transport (Mass, Loading and Access) Regulation 2005*, but does not exceed a dimension specified in Diagram 1 and Table 1 to this Notice.

2.1.3 The auger rear overhang (dimension A in Diagram 1) must not exceed 50 percent of the auger's overall length (dimension B in Diagram 1).

Diagram 1

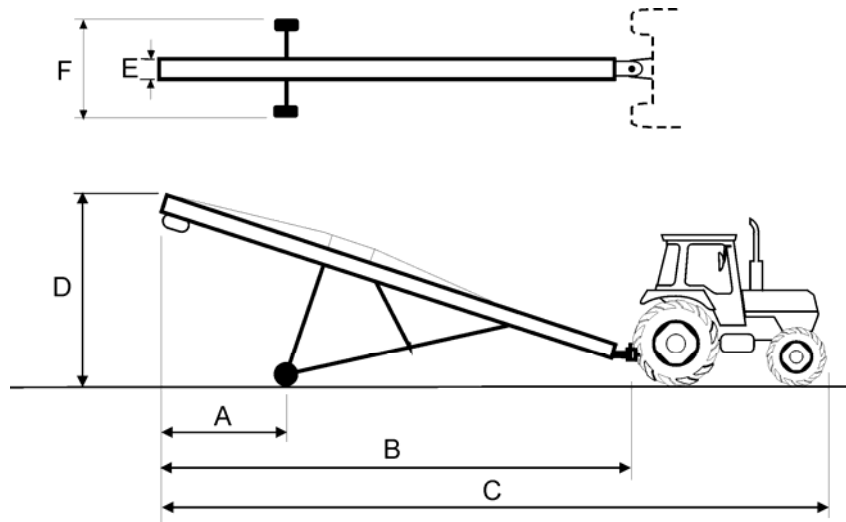

Table 1

Zone	Dimensions					
	A	B	C	D	E	F
Eastern	(up to) 8.0 m	(up to) 19.0 m	(up to) 25.0 m	(up to) 4.3 m	(up to) 0.75 m	(up to) 5.0 m
Western	(up to) 9.0 m	(up to) 19.0 m	(up to) 25.0 m	(up to) 4.3 m	(up to) 0.75 m	(up to) 6.0 m

Notes:

- For the purposes of this Notice, the Eastern Zone includes the Metropolitan Zones as defined in the General Class 1 Oversize (Agricultural Vehicle) Notice 2007.
- Where dimensions in this Notice are exceeded, an application for a specific permit must be sent to the Roads and Traffic Authority's Permits Unit for assessment. As a general rule, specific permits may be issued for up to 12 months for point-to-point travel within a 25km radius, or one-month permits may be issued for larger augers.

2.2 Operating Conditions and Requirements

2.2.1 A copy of this Notice, or an information sheet issued by the Roads and Traffic Authority setting out the obligations imposed under this Notice, must be carried in the driving compartment whenever operating as a grain auger combination and must be produced to a member of the police service or an authorised officer when requested.

2.3 Grain Auger Combination Specifications

2.3.1 The towing motor vehicle must be fitted with an efficient braking system capable of stopping the combination within the distance specified (in respect to the class of vehicle concerned) in clause 135 of Schedule 4 to the *Road Transport (Vehicle Registration) Regulation 1998*.

2.3.2 The mechanical connection between the towed and towing vehicles must comply with the applicable standards of Schedule 4 the *Road Transport (Vehicle Registration) Regulation 1998*.

2.3.3 A yellow warning light must be mounted on the vehicle and clearly visible at a distance of 500 metres in all directions, or be supplemented by one or more additional warning lights so that the light emanating from at least one of the lights is clearly visible at a distance of 500 metres in any direction.

2.3.4 Any warning light must be switched on when the combination is travelling or is stationary in a position that is likely to cause danger to other road users.

PART 3 – GLOSSARY OF TERMS

For the purpose of this Notice:

“authorised officer” means:

- in relation to the *Road Transport (General) Act 2005* or any provision of that Act, a person in the service of the Roads and Traffic Authority who is authorised by the Roads and Traffic Authority to exercise the functions of an authorised officer under that Act or those provisions; or

- a person authorised by the Roads and Traffic Authority to be an authorised person for the purposes of the *Road Transport (Vehicle Registration) Regulation 1998*.

“Eastern Zone” means the area to the east of the boundary defined by a line drawn through Corowa, Culcairn, Boorowa, Molong, Mudgee, Merriwa, Quirindi, Tamworth, Bundarra and Inverell to the Queensland border adjacent to the intersection of the Bonshaw–Emmaville Road and the Bruxner Highway (HW16) east of Bonshaw. For the purposes of this Notice, the Eastern Zone includes the Metropolitan Zones as defined in the General Class 1 Oversize (Agricultural Vehicle) Notice 2007.

“warning light” means a light that:

- (i) emits a rotating, flashing, yellow coloured light;
- (ii) flashes between 120 and 200 times a minute; and
- (iii) has a power of at least 55 watts.

“Western Zone” means the area to the west of the boundary defined by a line drawn through Corowa, Culcairn, Boorowa, Molong, Mudgee, Merriwa, Quirindi, Tamworth, Bundarra and Inverell to the Queensland border adjacent to the intersection of the Bonshaw–Emmaville Road and the Bruxner Highway (HW16) east of Bonshaw.
