

# Roads Transport (General) Act 2005

## Class 3 Semi-Trailer Exemption Notice 2008 under Part 2 of the Road Transport (Mass, Loading and Access) Regulation 2005

I, Les Wielinga, Chief Executive of the Roads and Traffic Authority, pursuant to clause 25 of the *Road Transport (Mass, Loading and Access) Regulation 2005*, do, by this Notice exempt from the dimension limits set out in Schedule 1 to the *Road Transport (Mass, Loading and Access) Regulation 2005*, the vehicles described in Part 2 of the Schedule subject to any condition or requirement set out in that Schedule.

Les Wielinga  
Chief Executive  
Roads and Traffic Authority

---

### SCHEDULE

#### PART 1 — PRELIMINARY

##### 1.1 Citation

This Notice may be cited as the Class 3 Semi-Trailer Exemption Notice 2008.

##### 1.2 Commencement

This Notice takes effect on 1 January 2008.

##### 1.3 Effect

This Notice remains in force until 31 December 2012 unless it is amended or repealed earlier.

##### 1.4 Interpretation

Unless stated otherwise, words and expressions used in this Notice have the same meaning as those defined in the Dictionary to the *Road Transport (Mass, Loading and Access) Regulation 2005*.

#### PART 2 — APPLICATION

##### 2.1 Application

2.1.1 This Notice applies provided that the vehicle, of the kind described in 2.1.2, is operated in accordance with the provisions of Part 3 - Operating and Travel Requirements.

2.1.2 This Notice applies to a semi-trailer (including a pole-type trailer) that exceeds the dimension limit specified in clause 73 (1) (b) of Schedule 2 to the *Road Transport (Vehicle Registration) Regulation 2007*, or a dimension limit specified in clause 7 of Schedule 1 to the *Road Transport (Mass, Loading and Access) Regulation 2005*, but does not exceed the dimension limits specified in Diagram 1 and Table 1 to this Notice.

**DIAGRAM 1**

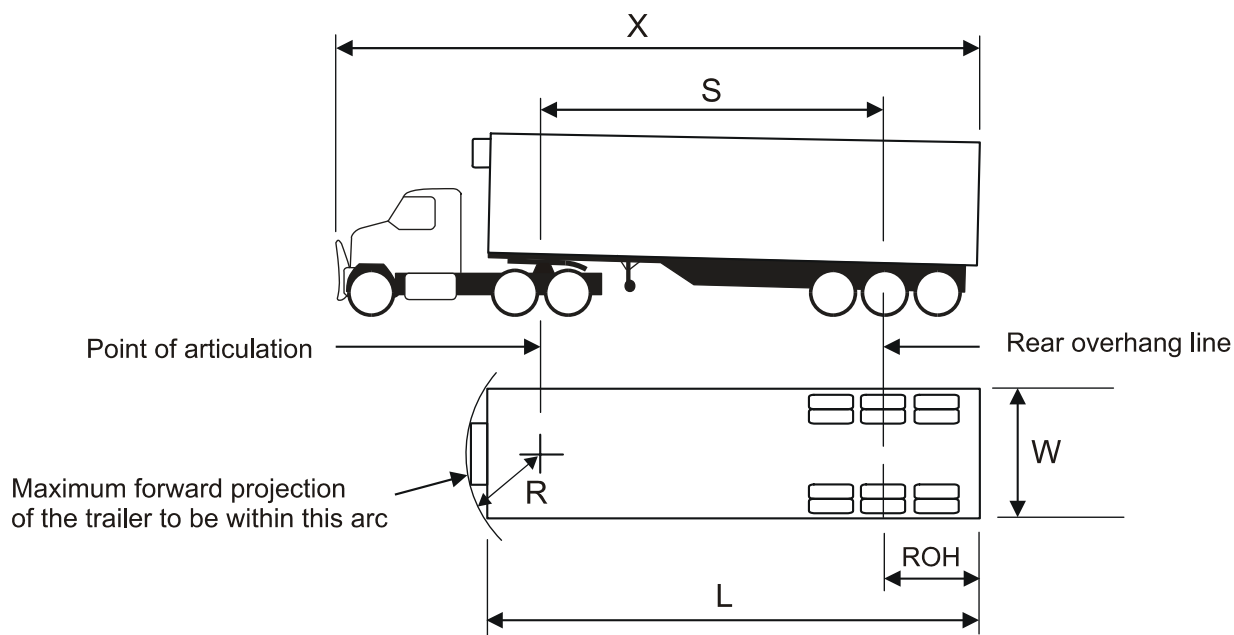

**TABLE 1**

<b>MAXIMUM DIMENSIONS</b>					
<b>L</b>	<b>R</b>	<b>S</b>	<b>W</b>	<b>X</b>	<b>ROH</b>
<b>14.63 m</b>	<b>1.9 m</b>	<b>9.5 m</b>	<b>2.5 m</b>	<b>19.0 m</b>	<b>3.7 m</b>

**Note:**

The length of the semi-trailer does not include any refrigeration or other auxiliary equipment or any loading space of a reduced width at the front of the semi-trailer.

**PART 3 — OPERATION AND TRAVEL REQUIREMENTS**

**3.1 Notice to be carried**

A copy of this Notice must be carried in the driving compartment of the prime-mover hauling a semi-trailer operating under this Notice, and must be produced to a police officer or an authorised officer when requested.

**3.2 Compliance plate denoting overdimension**

A semi-trailer to which this notice applies must be fitted with a compliance plate denoting that the vehicle is overdimension or must have an engineering certificate issued by an Engineering Signatory under the RTA Engineering Certificate Scheme or, a Compliance Certificate issued by a Recognised Signatory under the RTA Vehicle Compliance Certification Scheme, to show that the semi-trailer has been modified to comply with the applicable ADRs at the time of certification and fits the dimensions outlined in Table 1.

The engineering certificate must be carried in the vehicle with this notice at all times.

### **3.3 Class 3 semi-trailers and crates for livestock require specific permit**

A semi-trailer or crate for transporting livestock may exceed 13.7 metres, but not 14.63 metres in length, if operated in accordance with a specific permit issued by the Roads and Traffic Authority.

A semi-trailer or crate for transporting livestock may exceed 13.7 metres, but not 14.63 metres in length, if operated in accordance with the following specifications

1. Have only a single deck if transporting cattle, and
2. Have only two decks if transporting sheep, pigs or goats, and
3. The lower deck must be fully loaded before the upper deck is used, and
4. Not be a trailer specifically designed for transporting horses, and
5. The distance from the lowest deck to the top of the trailer must not exceed 2.1 metres.

### **3.4 Class 3 semi-trailer not to be used in B-Double or Road Train**

A semi-trailer operating under this Notice cannot be used as part of a B-Double or Road Train combination.